



LUXSOLAR® CATALOGUE

Heliport and Helideck Lighting

rev_250108



www.luxsolar.com

Luxsolar® is a department
of CE2K S.r.l.

LUXSOLAR



Luxsolar and LXS – registered trademarks of CEZK S.r.l. – identify a series of special lighting suitable both for potentially explosive atmospheres and safe areas.

Today, after a decade marked by a growing global market presence, Luxsolar has become one of the few manufacturers in the World able to provide not only LED Aircraft Warning Lights but also a complete range of Heliport and Helideck beacons.

All LUXSOLAR products, designed and manufactured in Italy, are the result of a constant R&D activity performed in-house.

Luxsolar mission is to create innovative products that combine high-tech and sustainable features. Our aim is to offer tailor-made lighting solutions in compliance to local and international regulations for airports, heliports, marine environments and elevated structures.

A handwritten signature in black ink, appearing to read 'Roberto', is positioned above the LUXSOLAR logo.

LUXSOLAR

#everything is made for passion

INDEX

| | |
|---|----|
| PRODUCT LINE FOR SURFACE HELIPORT..... | 4 |
| PRODUCT LINE FOT ELEVATED HELIPORT..... | 5 |
| HELIPORT LIGHTS - SAFE AREA | |
| PERIMETER LIGHT TLOF..... | 8 |
| PERIMETER LIGHT FATO..... | 10 |
| PERIMETER LIGHT TLOF-LXS-INSET..... | 12 |
| PERIMETER LIGHT FATO-LXS-INSET..... | 14 |
| AIMING POINT LIGHT INSET..... | 16 |
| FLIGHT PATH ALIGNMENT GUIDANCE LIGHT INSET..... | 18 |
| TDPC LIGHTING - LIGHTING SECTIONS..... | 20 |
| PERIMETER LIGHT - TLOF FLAT..... | 22 |
| PERIMETER LIGHT - FATO FLAT..... | 24 |
| H MARKING LIGHTING - LIGHTING SECTIONS..... | 26 |
| CROSS CHEVRON LIGHTING - LIGHTING SECTIONS..... | 28 |
| HELIPORT BEACON - HB..... | 30 |
| APPROACH LIGHT - FLASHING LIGHT..... | 34 |
| APPROACH LIGHT - STEADY BURNING LIGHT..... | 38 |
| HELIHOIST STATUS LIGHT..... | 42 |
| HELIPORT WINDSOCK..... | 46 |
| HELIPORT FLOODLIGHT..... | 50 |
| REPEATER STATUS LIGHT..... | 54 |
| LXS PORTABLE LIGHTING SYSTEM LXS-RESCUE..... | 60 |
| RADIO RECEIVER..... | 64 |
| HELIDECK LIGHTS - HAZARDOUS AREA | |
| PRODUCT LINE FOR HELIDECK..... | 68 |
| HELIDECK LIGHTS - HAZARDOUS AREA..... | 70 |
| REPEATER STATUS LIGHT EX D IIC..... | 76 |
| HELIDECK STATUS WAVE OFF LIGHT..... | 78 |
| REPEATER LIGHT EX..... | 80 |
| HELIDECK WINDSOCK..... | 82 |

HELIPORT AND HELIDECK LIGHTS

TYPICAL INSTALLATION SURFACE LEVEL HELIPORT (Land)

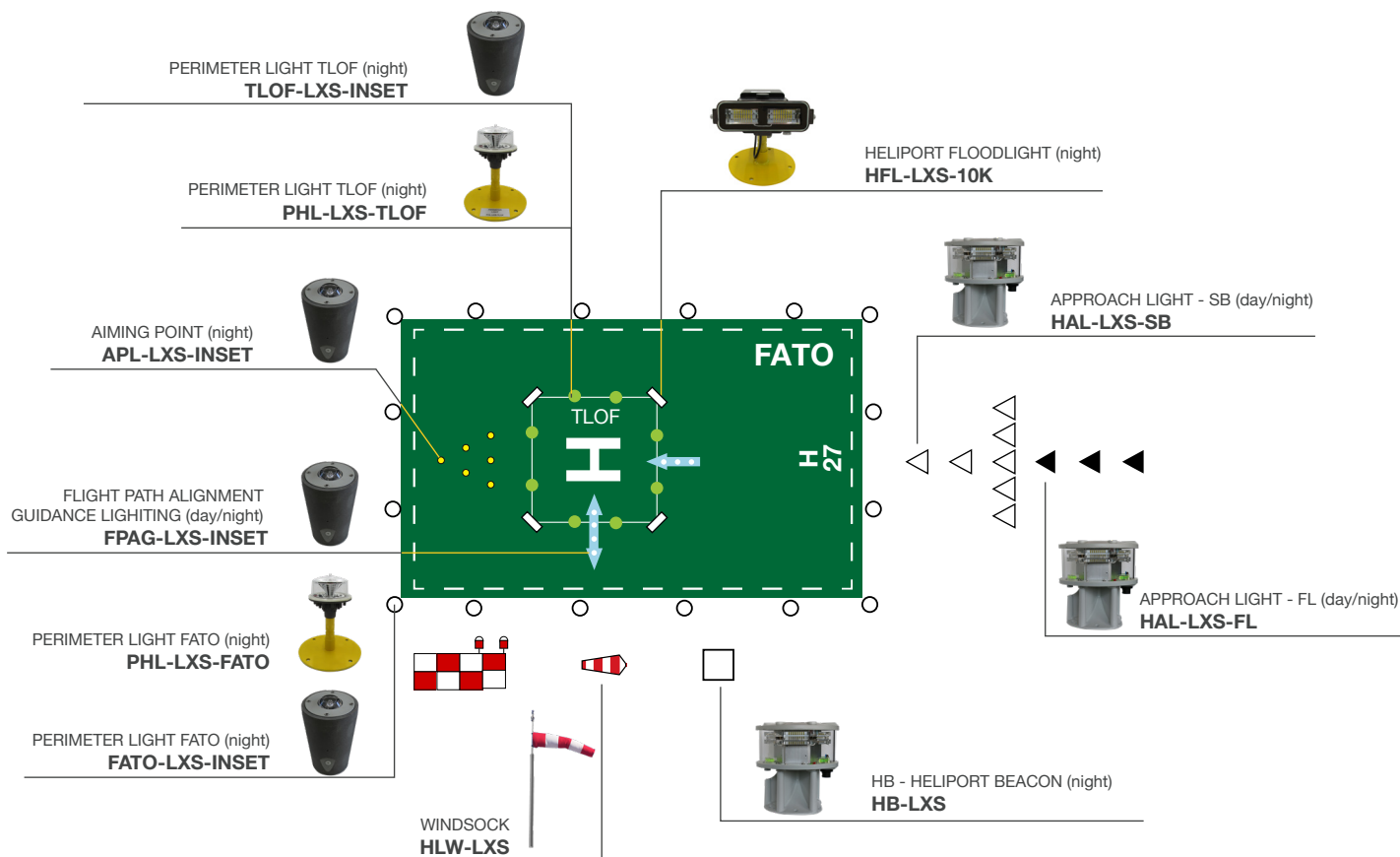

LEGEND

- | | | |
|--|---|---------------------------|
| HB - HELIPORT BEACON - HB-LXS | HELIPORT FLOODLIGHT - HFL-LXS-10K | OBSTRUCTION LIGHT* |
| APPROACH LIGHT Steady Burning - HAL-LXS-SB | PERIMETER LIGHT FATO - PHL-LXS-FATO | WINDSOCK - HLW-LXS |
| APPROACH LIGHT Flashing Lights - HAL-LXS-FL | PERIMETER LIGHT TLOF - PHL-LXS-TLOF or TLOF-LXS-INSET | |
| AIMING POINT LIGHT - APL-LXS-ONE-INSET | FLIGHT PATH ALIGNMENT GUIDANCE LIGHTING - FPAG-LXS-ONE-INSET | |

Heliport: an aerodrome or a defined area intended to be used for the arrival, departure and surface movement of helicopters.

(ICAO Aerodromes Annex 14 - Volume II Heliports - International Standards and Recommended Practices - Chapter 1.1-Definitions)

*OBSTRUCTION LIGHT: LUXSOLAR has a complete product range for obstruction light. Download Obstruction light catalogue at www.luxsolar.com



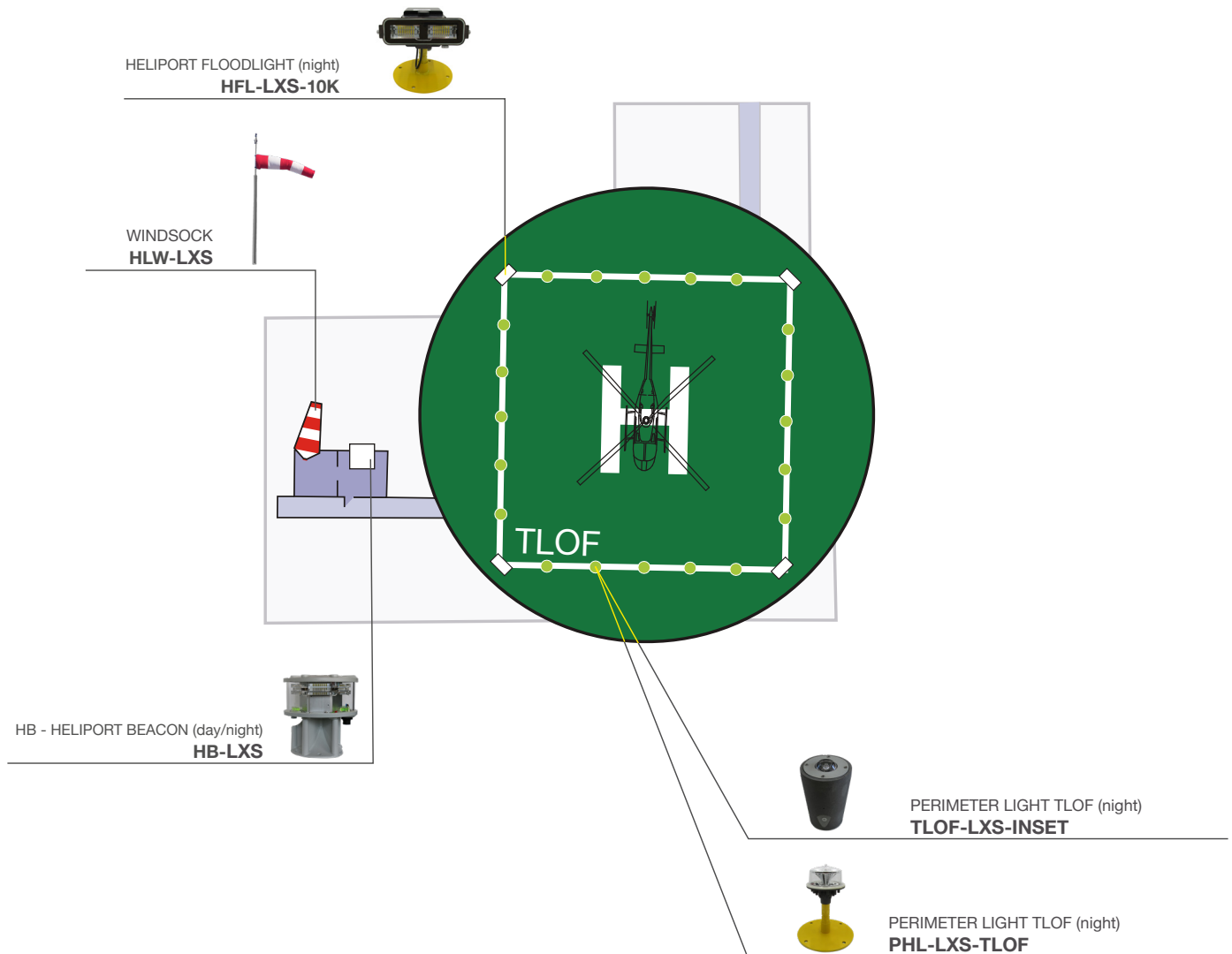

HELIPORT AND HELIDECK LIGHTS

TYPICAL INSTALLATION

ELEVATED HELIPORT (Skyscrapers, Buildings)



LEGEND

-  HB - HELIPORT BEACON - **HB-LXS**
-  HELIPORT FLOODLIGHT - **HFL-LXS-10K**
-  PERIMETER LIGHT TLOF - **PHL-LXS-TLOF** or **TLOF-LXS-INSET**
-  WINDSOCK MAST - **HLW-LXS**

Elevated Heliport: heliport located on a raised structure on land.

(ICAO Aerodromes Annex 14 - Volume II Heliports - International Standards and Recommended Practices - Chapter 1.1-Definitions)





HELIPORT LIGHTS

PERIMETER LIGHT - TLOF ELEVATED PHL-LXS-TLOF



- **Steady burning GREEN light**
- Long life time >10 years life expectancy
- Low consumption
- **Stabilised light output**
- **Lightweight and compact**
- Low wind load factor
- Easy to install
- No RF-radiations

PATENTED

INSTALLATION MAPS

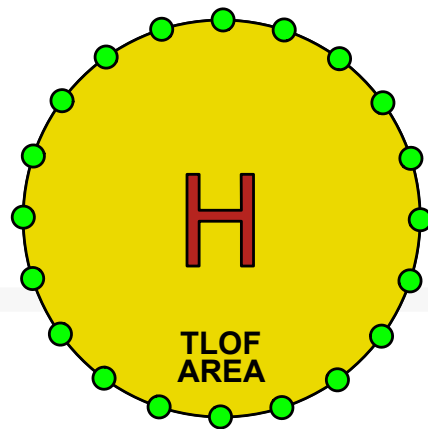
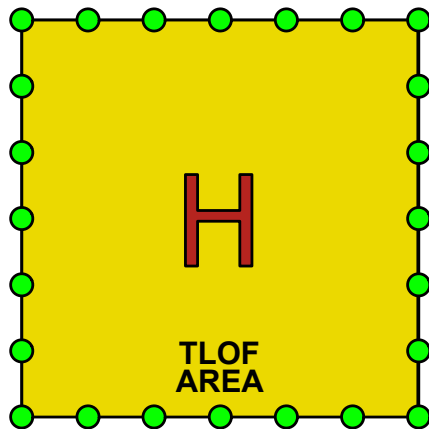

CERTIFICATION



FEATURES



TYPICAL APPLICATION



HELIPORT LIGHTS

PERIMETER LIGHT - TLOF ELEVATED TECHNICAL SPECIFICATION AND DRAWING

OPTICAL FEATURES

- Horizontal beam radiation 360°
- Optical reflector

| Elevation (E) | Luminous Intensity |
|-------------------------------|--------------------|
| $20^\circ < E \leq 90^\circ$ | 3 cd |
| $13^\circ < E \leq 20^\circ$ | 8 cd |
| $10^\circ < E \leq 13^\circ$ | 15 cd |
| $5^\circ < E \leq 10^\circ$ | 30 cd |
| $2^\circ \leq E \leq 5^\circ$ | 15 cd |

-180° Azimuth +180°

MECHANICAL FEATURES

- Anodised aluminium body with heat-sink pins for maximum heat dissipation
- Polycarbonate UV resistant dome
- Polyurethane foam
- Degree of protection: IP66
- Operating temperature: -20°C to +50°C
- Lamp c/w support unit weight: 2,5kg
- Anticondensation Goretex valve
- Frangible support included

COMPLIANCE

- ICAO Aerodromes -Annex 14 Volume 2, Heliports
- EASA CS-HPT-DSN

ELECTRICAL FEATURES

- Power Supply:
 - 24 VDC stand-alone version
 - 115/230 VAC stand-alone version
 - From control panel for light system
- Power consumption: 4W
- LED feded at costant current

OPTIONS

- Adjustable intensity OFF -3%, -10%, -100% from control panel only
- IR Wavelength - 850nm, compatible with pilot's NVG

CERTIFICATIONS

- EASA and ICAO test report (EN17025 laboratory) nr. 326-QL20-R08
- CE marking

ORDER CODE

PHL-LXS-TLOF-

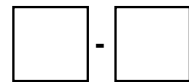

DC = 24 VDC
AC = 115/230 VAC
8 = From Control Panel

IR = Infrared

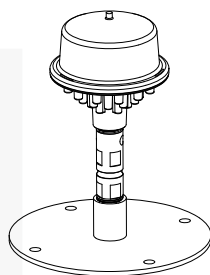
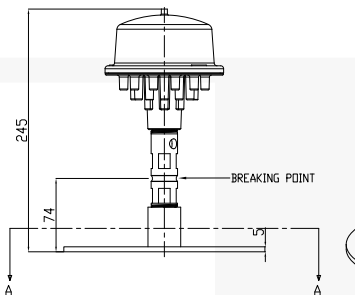
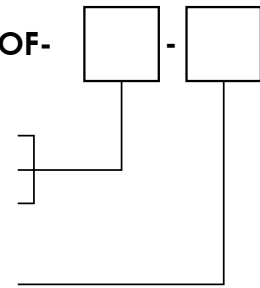

24 VDC version



115/230 VAC version

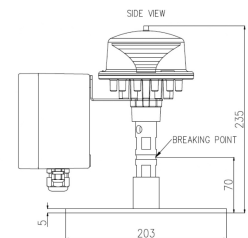

FRONT VIEW

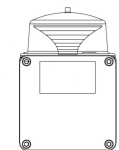

INCOMING POWER SUPPLY CABLE
7/4 CABLE (LAND 150 W/2021.5)

TLOF BEACON POWER SUPPLY CABLE
0/7 CABLE (LAND 150 W/2021.5)
0/4 CABLE (LAND 150 W/142)

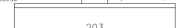

HELIPORT LIGHTS

PERIMETER LIGHT - FATO ELEVATED PHL-LXS-FATO

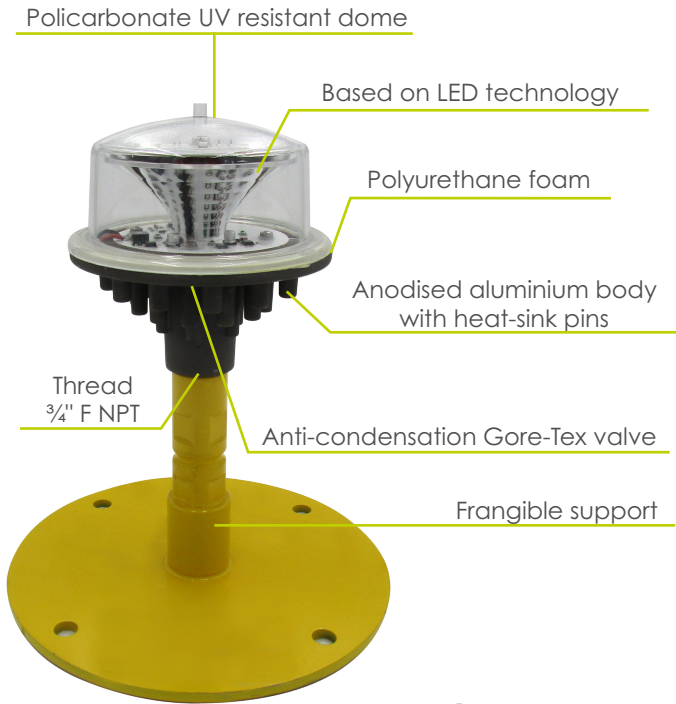

- **Steady burning WHITE light**
- **Long life time >10 years life expectancy**
- **Low consumption**
- **Stabilised light output**
- **Lightweight and compact**
- **Low wind load factor**
- **Easy to install**
- **No RF-radiations**

PATENTED

INSTALLATION MAPS

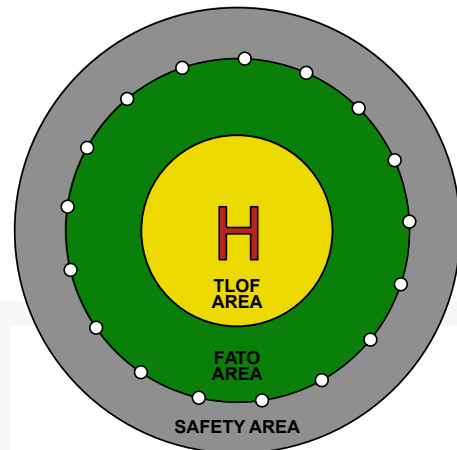
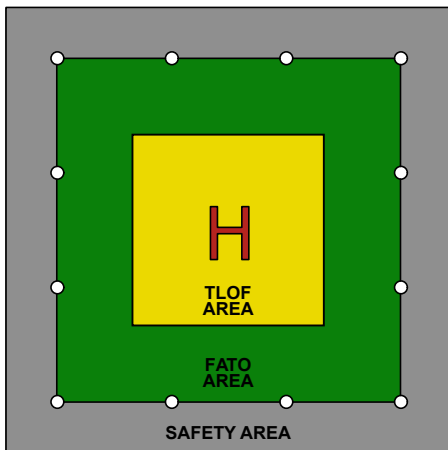

CERTIFICATION



COMPLIANCE



FEATURES



TYPICAL APPLICATION



HELIPORT LIGHTS

PERIMETER LIGHT - FATO ELEVATED TECHNICAL SPECIFICATION AND DRAWING

OPTICAL FEATURES

- Horizontal beam radiation 360°
- Optical reflector

| Elevation | Luminous Intensity |
|-----------|--------------------|
| 30° | 10 cd |
| 25° | 50 cd |
| 20° | 100 cd |
| 10° | 100 cd |
| 3° | 100 cd |
| 0° | 10 cd |

-180° Azimuth +180°

MECHANICAL FEATURES

- Anodised aluminium body with heat-sink pins for maximum heat dissipation
- Polycarbonate UV resistant dome
- Polyurethane foam
- Degree of protection: IP66
- Operating temperature: -20°C to +50°C
- Lamp c/w support unit weight: 2,5kg
- Anticondensation Goretex valve
- Frangible support included

COMPLIANCE

- ICAO Aerodromes -Annex 14 Volume 2, Heliports
- EASA CS-HPT-DSN

ELECTRICAL FEATURES

- Power Supply:
 - 24 VDC stand-alone version
 - 115/230 VAC stand-alone version
 - From control panel for light system
- Power consumption: 4W
- LED feeded at constant current

OPTIONS

- Adjustable intensity OFF -3%, -10%, -100% from control panel only
- IR Wavelength - 850nm, compatible with pilot's NVG

CERTIFICATIONS

- CE marking

ORDER CODE

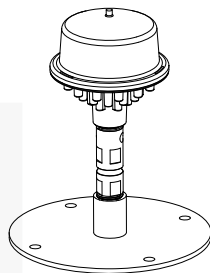
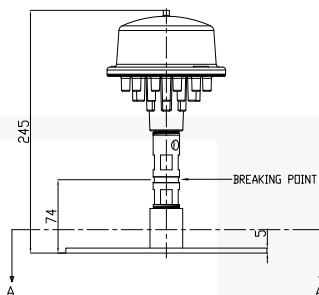
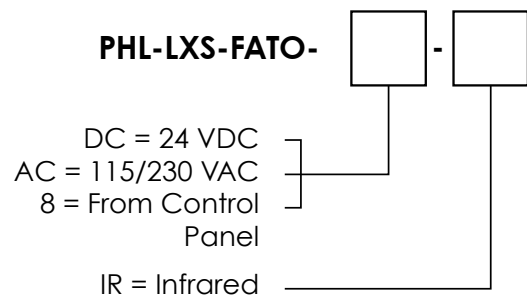

24 VDC version



115/230 VAC version

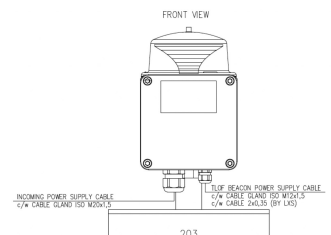
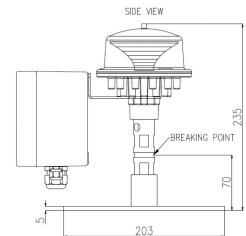

HELIPORT LIGHTS

PERIMETER LIGHT - TLOF INSET TLOF-LXS-INSET



Defines the perimeter of TLOF. As it is built-in, it requires the construction of a well in the flooring of the surface. Suitable for both ground and elevated platforms.

- Steady green light
- Lifetime higher than 10 years
- Low consumption
- Stabilised light output
- Compact and light structure
- Easy to install
- No RF-radiations



INSTALLATION MAPS

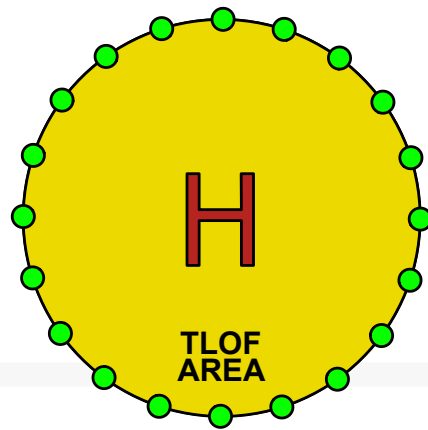
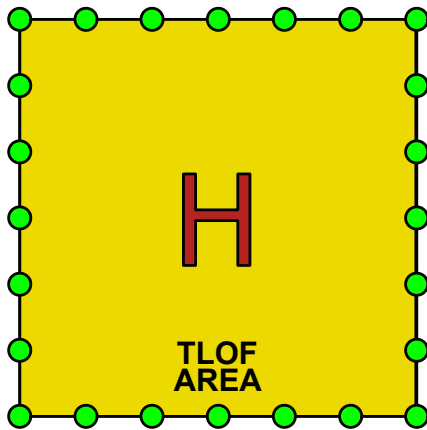

LEGEND

- TLOF-LXS-INSET

NOTE: the number of TLOF perimeter lights required by legislation is strictly dependent on the size of the TLOF area in question.

On elevated platforms, in most cases the TLOF area coincides with the FATO area, so the installation of TLOF perimeter lights only is required.

CERTIFICATION



FEATURES



HELIPORT LIGHTS

PERIMETER LIGHT - TLOF INSET TECHNICAL SPECIFICATIONS

OPTICAL FEATURES

- Horizontal emission: 360°
- PMMA and tempered glass lenses

| Elevation (E) | Luminous Intensity |
|-------------------------------|--------------------|
| $20^\circ < E \leq 90^\circ$ | 3 cd |
| $13^\circ < E \leq 20^\circ$ | 8 cd |
| $10^\circ < E \leq 13^\circ$ | 15 cd |
| $5^\circ < E \leq 10^\circ$ | 30 cd |
| $2^\circ \leq E \leq 5^\circ$ | 15 cd |

-180° Azimuth +180°

MECHANICAL FEATURES

- SS316 body
- NBR o-ring
- Degree of protection: IP68 (1,2 m x 45 min)
- Shallow base 5"
- Operating temperature: -20°C to +60°C
- Supplied with 30cm LUXSOLAR standard cable
- Weight: 4,8kg
- Tempered glass max load 5 ton

COMPLIANCE

- ICAO Aerodromes - Annex 14 Volume 2, Heliports
- EASA CS-HPT-DSN

ELECTRICAL FEATURES

- Power Supply:
 - 24 VDC stand-alone version
 - From control panel for light system
- Consumption: 3,7W @12/24Vdc
- Constant current driven LED
- Light intensity adjustment: 10% - 30% - 100%

OPTIONS

- Adaptor for shallow base 8"/ 12"
- Wave length IR: 850nm, compatible with NVG pilot

CERTIFICATION

- CE marking
- ICAO/EASA test report nr.1407-QL22-R01 (lab. EN17025)

ORDER CODE

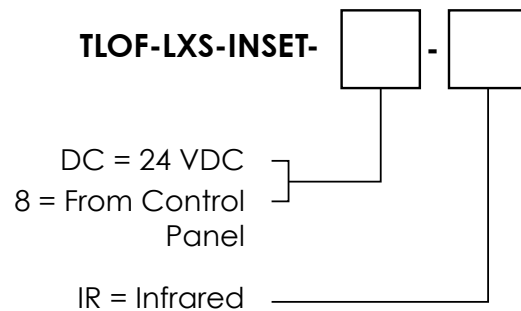

TECHNICAL DRAWINGS

TOP VIEW

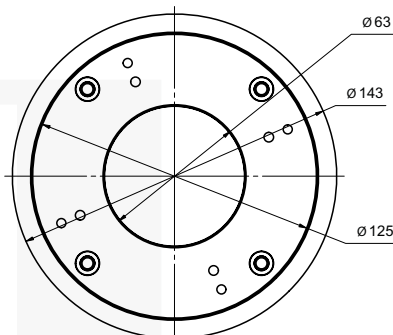

SIDE VIEW

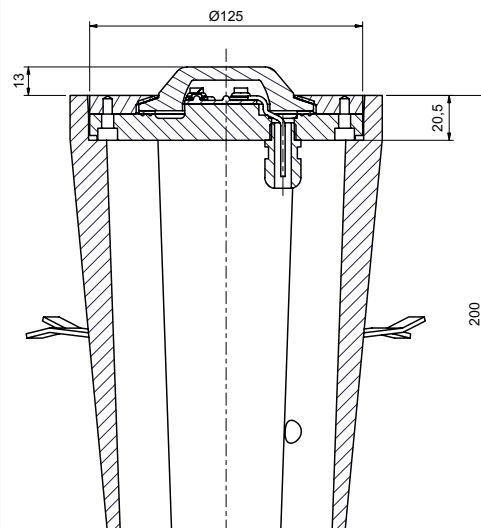

HELIPORT LIGHTS

PERIMETER LIGHT - FATO INSET FATO-LXS-INSET



PATENTED

Installed at the edges of the FATO AREA, defining its perimeter. It has a recessed and driveway structure that requires the construction of a well inside the flooring of the surface. Alternatively, it is possible to install the product code PHL-LXS-FATO or FATO-LXS-FLT.

- Steady white light
- Lifetime higher than 10 years
- Low consumption
- Stabilised light output
- Compact and light structure
- Easy to install
- No RF-radiations

INSTALLATION MAPS

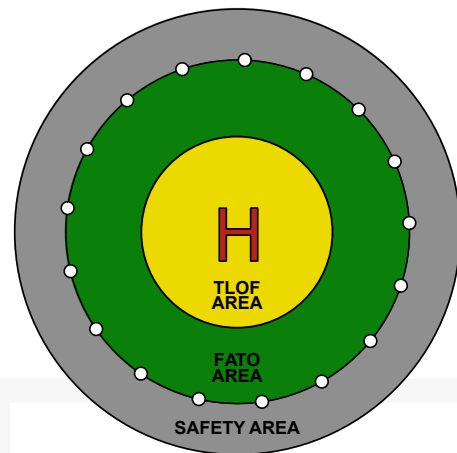
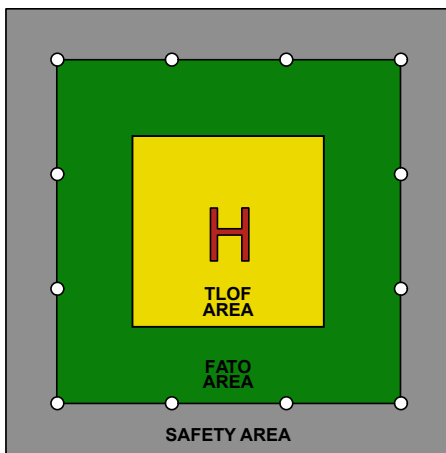

LEGEND

○ PHL-LXS-FATO

NOTE: for HEMS elevated surfaces, the FATO area coincides with TLOF area therefore, in the major part of installations, FATO perimeter lights are not provided.

CERTIFICATION



FEATURES



HELIPORT LIGHTS

PERIMETER LIGHT - FATO INSET TECHNICAL SPECIFICATION

OPTICAL FEATURES

- Horizontal emission: 360°
- PMMA and tempered glass lenses

| Elevation (E) | Luminous Intensity |
|---------------|--------------------|
| 30° | 10 cd |
| 25° | 50 cd |
| 20° | 100 cd |
| 10° | |
| 3° | |
| 0° | 10 cd |

-180° Azimuth +180°

MECHANICAL FEATURES

- SS316 body
- NBR o-ring
- Degree of protection IP68 (1,2mx45min)
- Shallow base 5"
- Operating temperature: -20°C to +60°C
- Supplied with 30cm LUXSOLAR standard cable
- Weight: 4,8 Kg
- Tempered glass max load 5 ton

COMPLIANCE

- ICAO Aerodromes - Annex 14 Volume 2, Heliports
- EASA CS-HPT-DSN

ELECTRICAL FEATURES

- Power Supply:
 - 24 VDC stand-alone version
 - From control panel for light system
- Consumption: 3,7W @12/24Vdc
- Constant current driven LED
- Light intensity adjustment: 10% - 30% - 100%

OPTIONS

- Adaptor for shallow base 8"/ 12"
- IR wavelength: 850nm, compatible with NVG pilot

CERTIFICATION

- CE marking
- ICAO/EASA test report 1407-QL22-R04 (lab. EN17025)

ORDER CODE

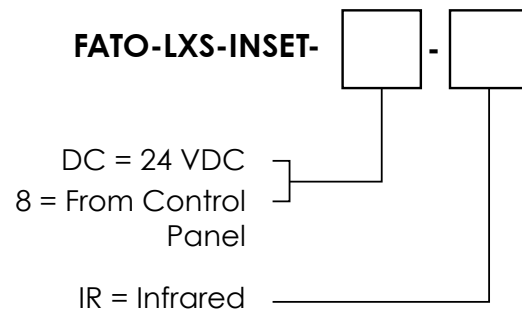

TECHNICAL DRAWINGS

TOP VIEW

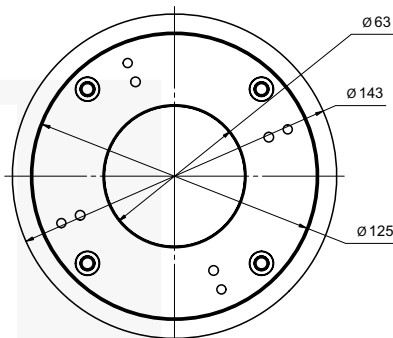

SIDE VIEW

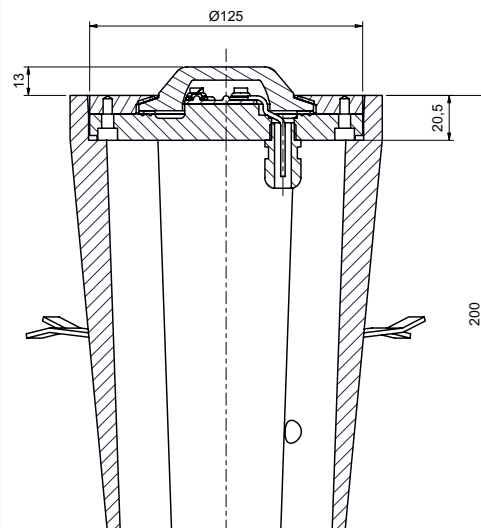

HELIPORT LIGHTS

AIMING POINT LIGHT INSET APL-LXS-INSET



An aiming point lighted marking should be provided at a heliport where it is necessary to make an approach to a particular point above a FATO before proceeding to a TLOF.

- **Steady burning WHITE light**
- Long life time >10 years life expectancy
- **Low consumption**
- **Stabilised light output**
- **Easy to install**
- **No RF-radiations**
- Compact and light structure

PATENTED

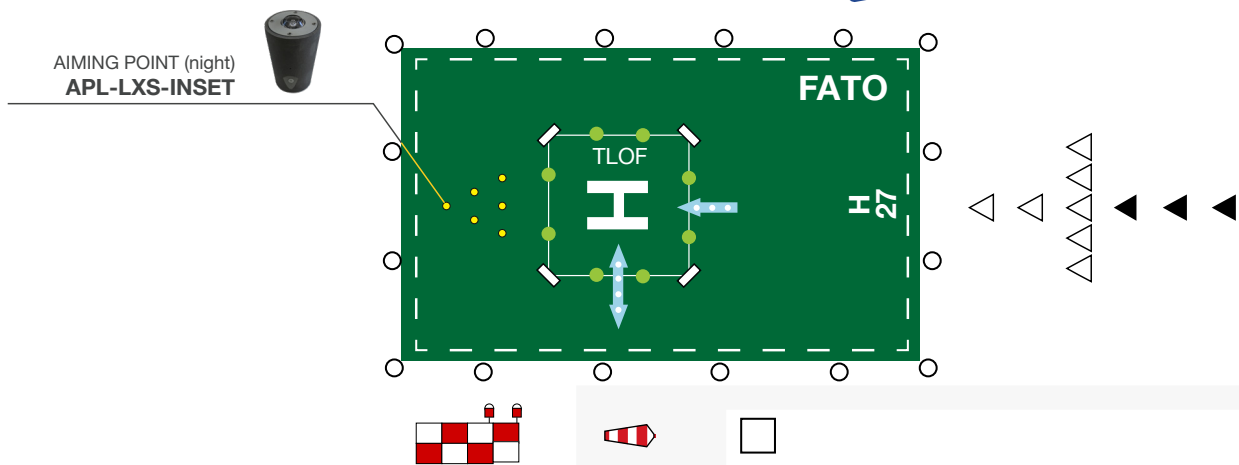

CERTIFICATION



FEATURES



TYPICAL APPLICATION



HELIPORT LIGHTS

AIMING POINT LIGHT INSET TECHNICAL SPECIFICATION AND DRAWING

OPTICAL FEATURES

- Horizontal emission: 360°
- PMMA and tempered glass lens

| Elevation (E) | Luminous Intensity |
|---------------|--------------------|
| 30° | 10 cd |
| 25° | 50 cd |
| 20° | 100cd |
| 10° | 100cd |
| 3° | 100 cd |
| 0° | 10 cd |

-180° Azimuth +180°

MECHANICAL FEATURES

- SS316 body
- NBR o-ring
- Tempered glass max load 5 ton.
- Degree of protection IP68 (1,2mx45min)
- Shallow base dimension: 5"
- Operating temperature: -20°C to +60°C
- Lamp unit weight c/w shallow base 4,8Kg

COMPLIANCE

- ICAO Aerodromes - Annex 14 Volume 2, Heliports
- EASA CS-HPT-DSN

ELECTRICAL FEATURES

- Power Supply:
 - 24 VDC stand-alone version
 - From control panel for light system
- Consumption: 3,7W @12/24Vdc
- Constant current driven LED
- Light intensity adjustment: 10% - 30% - 100%

OPTIONS

- 8"/ 12"shallow base adapter
- IR wavelength 850nm, compatible with NVG pilot

CERTIFICATIONS

- ICAO/EASA test report (EN17025 laboratory) nr. 1407-QL22-R04
- CE marking

ORDER CODE

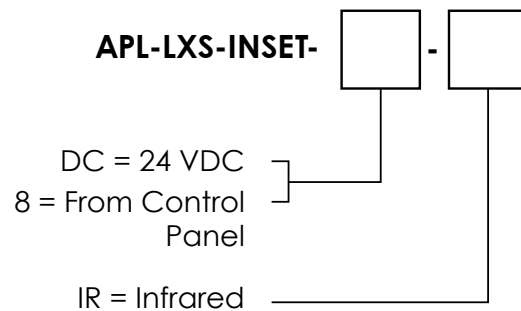

TECHNICAL DRAWINGS

TOP VIEW

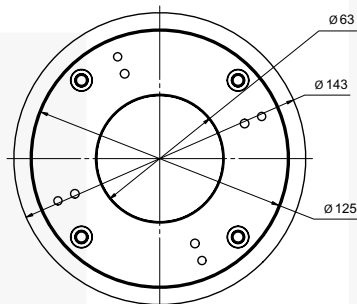

SIDE VIEW

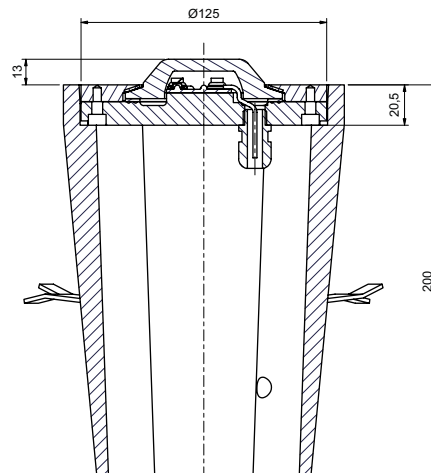

HELIPORT LIGHTS

FLIGHT PATH ALIGNMENT GUIDANCE LIGHT INSET FPAG-LXS-INSET



Where practicable, a flight path alignment guidance marking should be provided to indicate available approach and/or departure path directions.

- **Steady burning WHITE light**
- Long life time >10 years life expectancy
- Low consumption
- Stabilised light output
- Easy to install
- No RF-radiations
- Compact and light structure

PATENTED

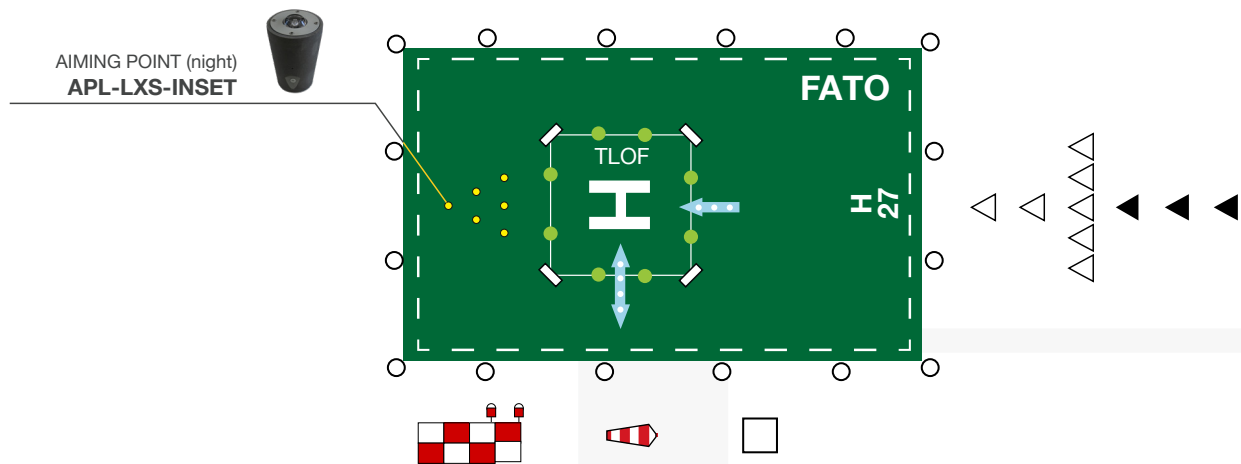

CERTIFICATION



FEATURES



TYPICAL APPLICATION



HELIPORT LIGHTS

FLIGHT PATH ALIGNMENT GUIDANCE LIGHT INSET TECHNICAL SPECIFICATION AND DRAWING

OPTICAL FEATURES

- Horizontal emission: 360°
- PMMA and tempered glass lens

| Elevation (E) | Luminous Intensity |
|-------------------------------|--------------------|
| $20^\circ < E \leq 90^\circ$ | 3 cd |
| $13^\circ < E \leq 20^\circ$ | 8 cd |
| $10^\circ < E \leq 13^\circ$ | 15 cd |
| $5^\circ < E \leq 10^\circ$ | 30 cd |
| $2^\circ \leq E \leq 5^\circ$ | 15 cd |

-180° Azimuth +180°

MECHANICAL FEATURES

- SS316 body
- NBR o-ring
- Tempered glass max load 5 ton.
- Degree of protection: IP68 (1,2mx45min)
- Shallow base dimension: 5"
- Operating temperature: -20°C to +60°C
- Lamp unit weight c/w shallow base 4,8kg

COMPLIANCE

- ICAO Aerodromes - Annex 14 Volume 2, Heliports
- EASA CS-HPT-DSN

ELECTRICAL FEATURES

- Power Supply:
 - 24 VDC stand-alone version
 - From control panel for light system
- Consumption: 3,7W @12/24Vdc
- Constant current driven LED
- Light intensity adjustment: 10% - 30% - 100%

OPTIONS

- 8"/ 12" shallow base adapter
- IR wavelength 850nm, compatible with NVG pilot

CERTIFICATIONS

- ICAO/EASA test report (EN17025 laboratory) nr. 1407-QL22-R04
- CE marking

ORDER CODE

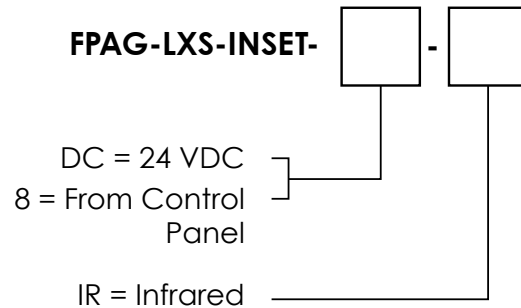

TECHNICAL DRAWINGS

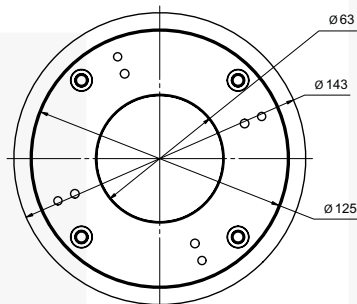

SIDE VIEW

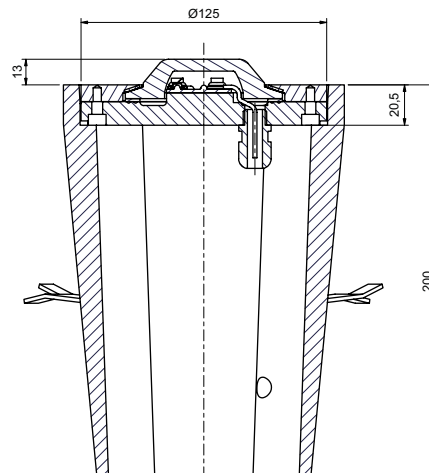

HELIPORT LIGHTS

TDPC LIGHTING- LIGHTING SECTIONS ASPSL-TDPC-LXS

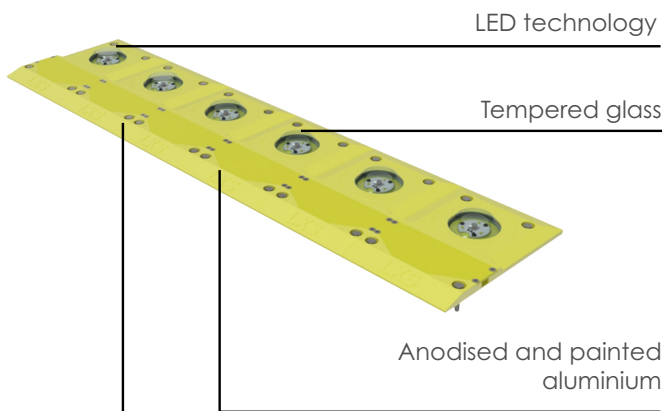

It marks the TDPC area circumference. The beacon is vehicle-accessible and suitable both for surface and elevated areas.

- Steady AMBER light
- Life time longer than 10 years
- Low consumption
- Stabilised light output
- Light-weight and compact body
- Easy to install
- No RF-radiations
- LED IR version available



INSTALLATION MAPS

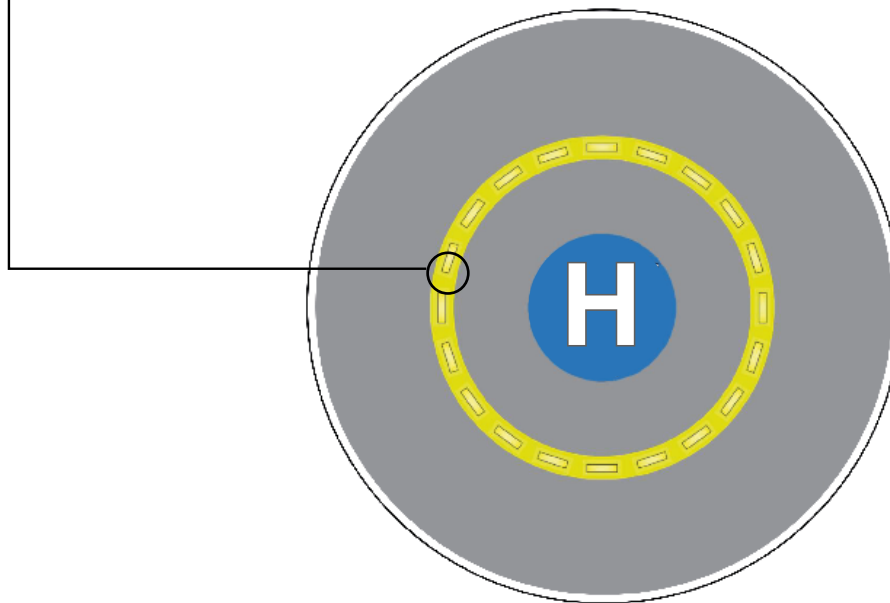

CAPTION

● ASPSL-LXS

Typical quantity of beacons to be installed is 16. For custom solutions (non-standard helipad dimensions) quantity of beacons shall be calculated.

CERTIFICATION



COMPLIANCE



FEATURES



HELIPORT LIGHTS

TDPC LIGHTING- LIGHTING SECTIONS TECHNICAL SPECIFICATIONS

OPTICAL FEATURES

- Horizontal beam radiation: 360°
- PMMA and tempered glass lens

| ELEVATION | LUMINOUS INTENSITY [cd] | |
|--------------|-------------------------|-----|
| | Min | Max |
| 0° to 10° | 11 | 60 |
| > 10° to 20° | 2,75 | 40 |
| > 20° to 90° | 0,55 | 15 |

-180° Azimuth +180°

MECHANICAL FEATURES

- Anodised and painted aluminium body
- EPDM o-ring
- Degree of protection: IP68
- Operating temperature: -20°C to +50°C
- Provided with Luxsolar standard cable 30cm
- Elevation: <25mm
- Tempered glass resistant up to 5000kg load

ELECTRICAL FEATURES

- Powered by LXS control panel:
 - 12/24 or 48 VDC or 115/230 VAC incoming power
 - 24 VDC outgoing power to the beacons
- Power consumption: 2W @24 VDC each element
- Adjustable light intensity: 10% - 30% - 100%
- Failures monitoring

OPTIONS

- IR Wavelength: 850nm, compatible with pilot's NVG

CERTIFICATIONS

- CE

COMPLIANCE

- ICAO Aerodromes- Annex 14, Volume 2, Heliports
- EASA CS-HPT-DSN
- EASA PTS-VPT-DSN
- CAA CAP1264

ORDER CODE

ASPSL-TDPC-LXS

TECHNICAL DRAWING

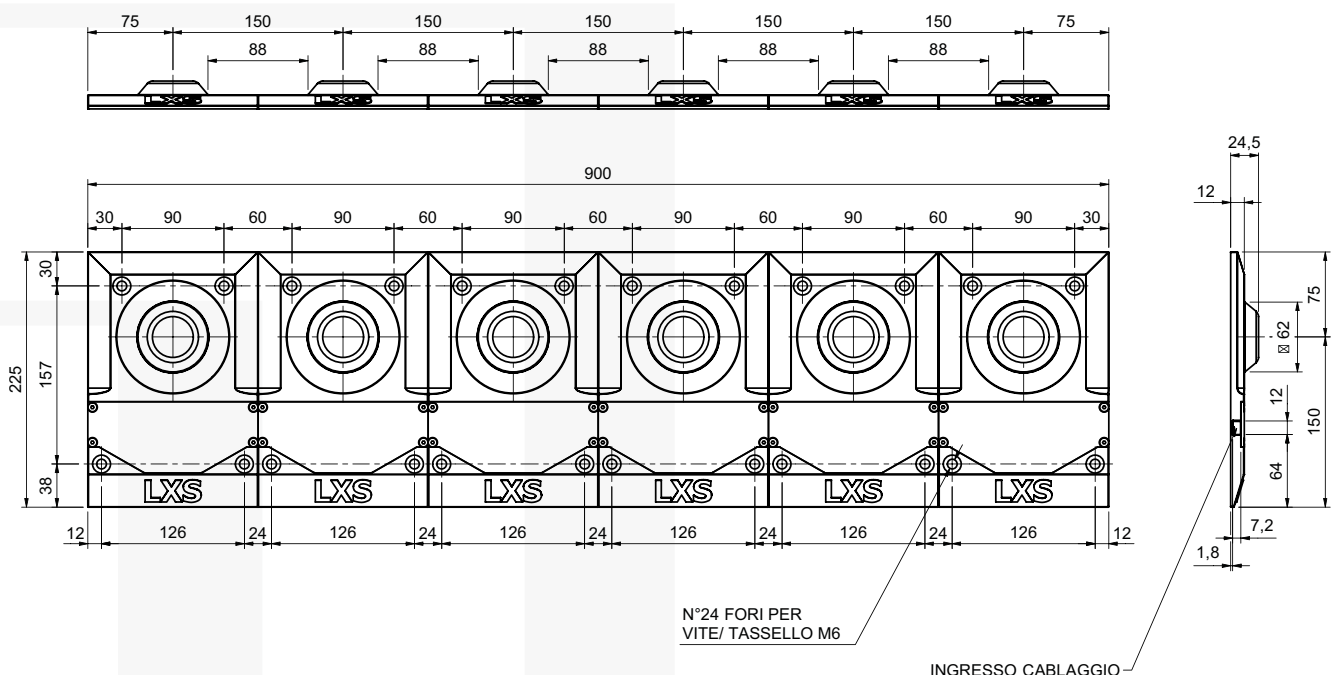

HELIPORT LIGHTS

PERIMETER LIGHT – TLOF FLAT TLOF-LXS-FLT

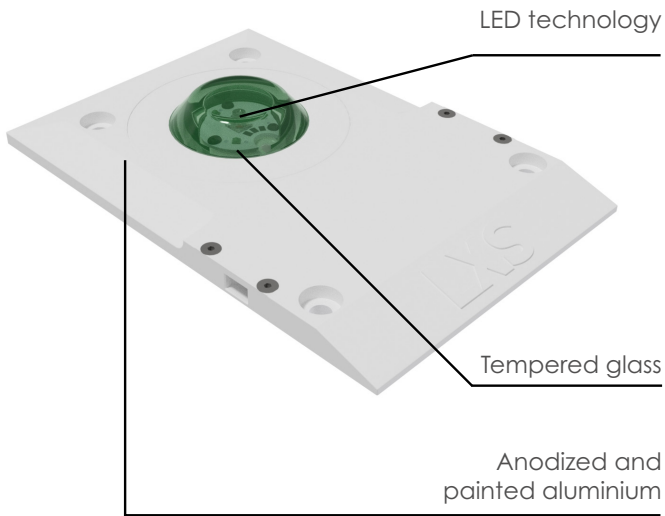

It marks perimetrically the TLOF area. The beacon is drive-over and no manhole on the surface is needed.

Suitable both for on and above ground platforms.

- Steady GREEN light
- Life time longer than 10 years
- Low consumption
- Stabilised light output
- Light-weight and compact body
- Easy to install
- No RF-radiations
- LED IR version available

PATENTED

INSTALLATION MAPS

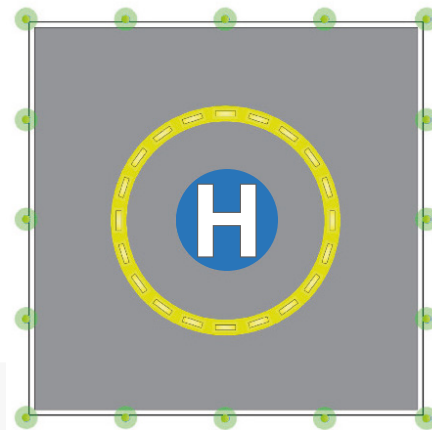
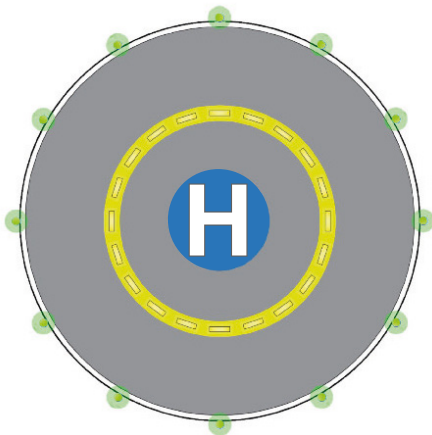

CAPTION

● TLOF-LXS-FLT

NOTE: The required-by-rules quantity of TLOF perimeter beacons is closely connected with the TLOF perimeter itself.

On above-ground platforms, the TLOF area mostly matches with the FATO area and that's the reason why the only TLOF perimeter beacons are required.

CERTIFICATION



COMPLIANCE



FEATURES



HELIPORT LIGHTS

PERIMETER LIGHT - TLOF FLAT TECHNICAL SPECIFICATIONS

OPTICAL FEATURES

- Horizontal beam radiation: 360°
- PMMA and tempered glass lens

| ELEVATION | LUMINOUS INTENSITY [cd] |
|-------------------------------|-------------------------|
| $20^\circ < E \leq 90^\circ$ | 3 |
| $13^\circ < E \leq 20^\circ$ | 8 |
| $10^\circ < E \leq 13^\circ$ | 15 |
| $5^\circ < E \leq 10^\circ$ | 30 |
| $2^\circ \leq E \leq 5^\circ$ | 15 |

-180° Azimuth +180°

MECHANICAL FEATURES

- Anodised and painted aluminium body
- EPDM o-ring
- Degree of protection: IP68
- Operating temperature: -20°C to +50°C
- Provided with Luxsolar standard cable 30cm
- Elevation: <25mm
- Tempered glass resistant up to 5000kg load

ELECTRICAL FEATURES

- Powered by LXS control panel:
 - 12/24 or 48 VDC or 115/230 VAC incoming power
 - 24 VDC outgoing power to the beacons
- Power consumption: 3,7W @12/24 VDC
- LED feeded at constant current
- Adjustable light intensity: 10% - 30% - 100%

OPTIONS

- IR Wavelength: 850nm, compatible with pilot's NVG

COMPLIANCE

- ICAO/EASA test report (EN17025 laboratory) nr. 1407-QL22-R01
- CE

COMPLIANCE

- ICAO Aerodromes - Annex 14 Volume 2, Heliports
- EASA CS-HPT-DSN
- EASA PTS-VPT-DSN

ORDER CODE

TLOF-LXS-FLT

TECHNICAL DRAWINGS

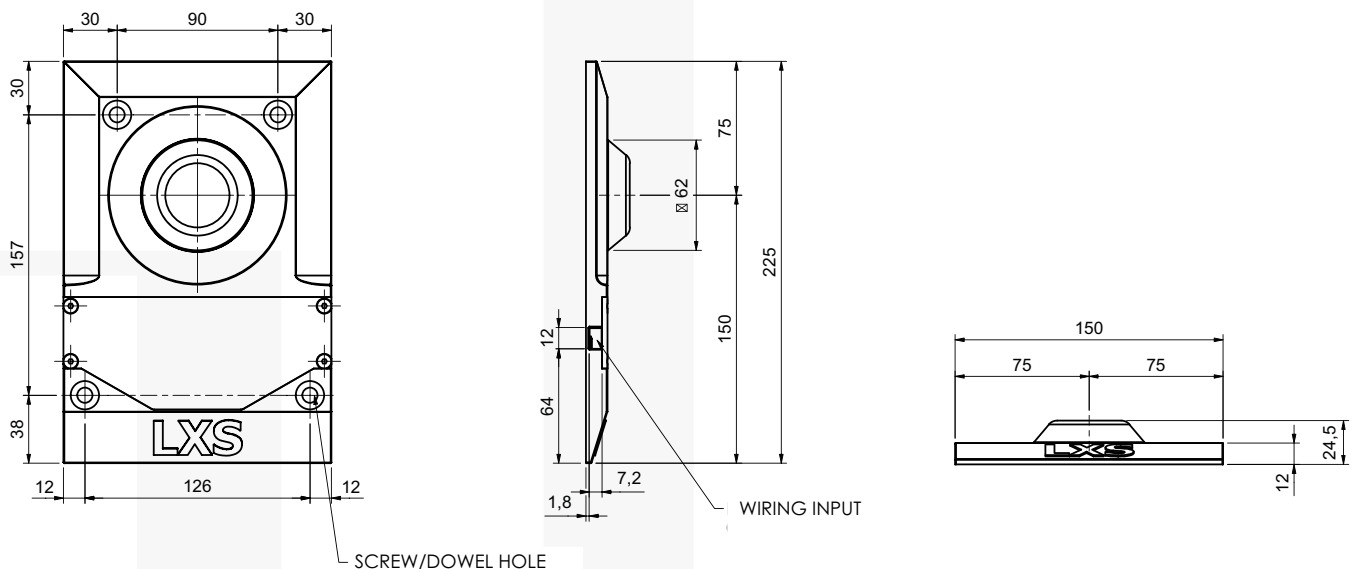

HELIPORT LIGHTS

PERIMETER LIGHT - FATO FLAT FATO-LXS-FLT

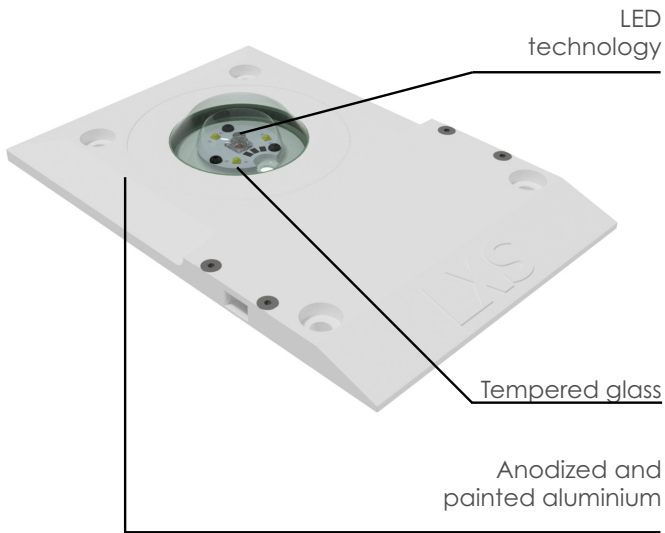

It marks perimetrically the FATO area. The beacon is drive-over and no manhole on the surface is needed.

Suitable both for on and above ground platforms.

- Steady WHITE light
- Life time longer than 10 years
- Low consumption
- Stabilised light output
- Light-weight and compact body
- Easy to install
- No RF-radiations
- LED IR version available

PATENTED

INSTALLATION MAPS

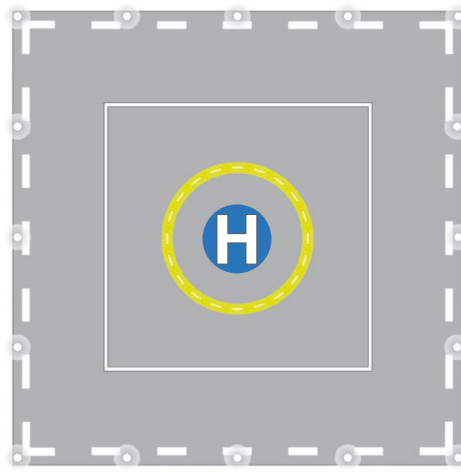

CAPTION

○ FATO-LXS-FLT

NOTE: The required-by-rules quantity of FATO perimeter beacons is closely connected with the FATO perimeter itself.

On above-ground platforms, the TLOF area mostly matches with the FATO area and that's the reason why the only TLOF perimeter beacons are required.

CERTIFICATION



COMPLIANCE



FEATURES



HELIPORT LIGHTS

PERIMETER LIGHT - FATO FLAT TECHNICAL SPECIFICATIONS

OPTICAL FEATURES

- Horizontal beam radiation: 360°
- PMMA and tempered glass lens

| ELEVATION | LUMINOUS INTENSITY [cd] |
|-----------|-------------------------|
| 30° | 10 |
| 25° | 50 |
| 20° | 100 |
| 10° | 100 |
| 3° | 100 |
| 0° | 10 |

-180° Azimuth +180°

MECHANICAL FEATURES

- Anodised and painted aluminium body
- EPDM o-ring
- Degree of protection: IP68
- Operating temperature: -20°C to +50°C
- Provided with Luxsolar standard cable 30cm
- Elevation: <25mm
- Tempered glass resistant up to 5000kg load

ELECTRICAL FEATURES

- Powered by LXS control panel:
 - 12/24 or 48 VDC or 115/230 VAC incoming power
 - 24 VDC outgoing power to the beacons
- Power consumption: 3,7W @12/24 VDC
- LED feeded at constant current
- Adjustable light intensity: 10% - 30% - 100%

OPTIONS

- IR Wavelength: 850nm, compatible with pilot's NVG

COMPLIANCE

- ICAO/EASA test report (EN17025 laboratory) nr. 1407-QL22-R04
- CE

COMPLIANCE

- ICAO Aerodromes - Annex 14 Volume 2, Heliports
- EASA CS-HPT-DSN
- EASA PTS-VPT-DSN

ORDER CODE

FATO-LXS-FLT

TECHNICAL DRAWINGS

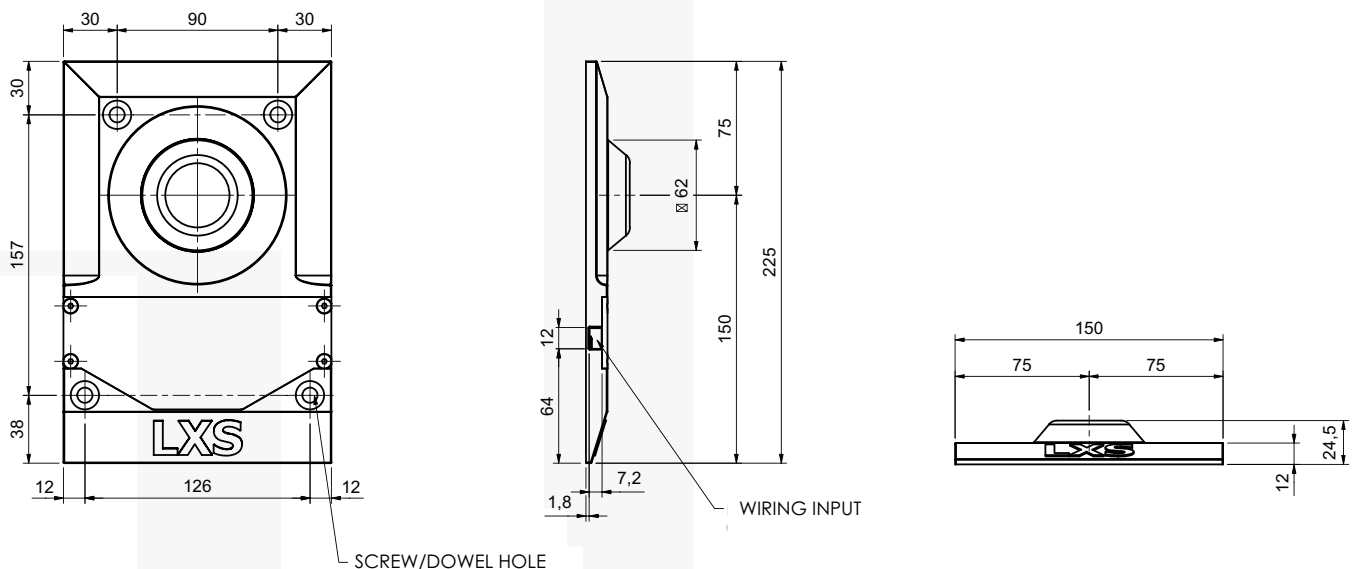

HELIPORT LIGHTS

H MARKING LIGHTING - LIGHTING SECTIONS CRH-LXS

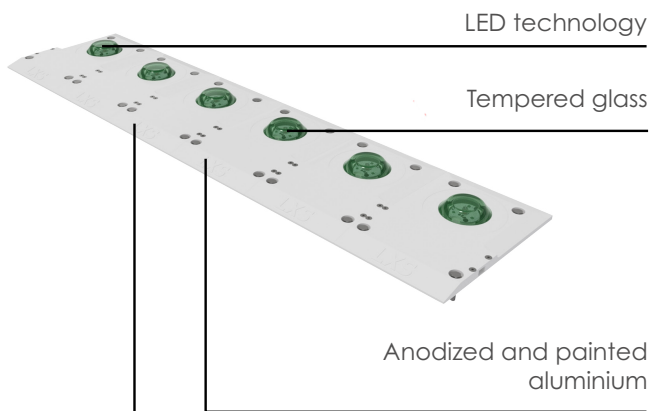

The H Marking Lighting marks the perimeter of the H symbol that is central in the TDPC area. The beacon is vehicle-accessible and suitable both for surface and elevated areas.

- Steady GREEN light
- Life time longer than 10 years
- Low consumption
- Stabilised light output
- Light-weight and compact structure
- Easy to install
- No RF-radiations
- IR version available

PATENTED

INSTALLATION MAPS

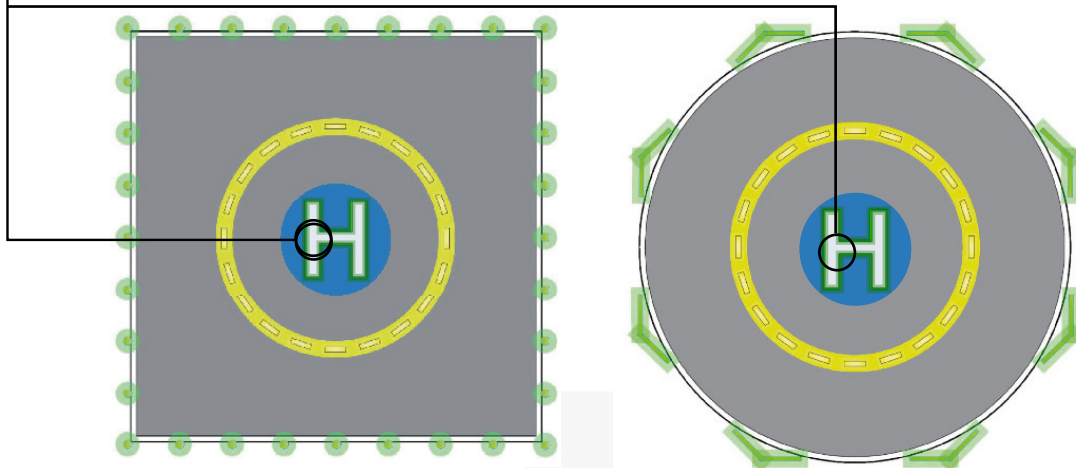

CAPTION

○ CRH-LXS

The quantity of the required-by-regulation beacons is closely connected with the to-be-illuminated symbol dimensions.

CERTIFICATION



COMPLIANCE



FEATURES



HELIPORT LIGHTS

H MARKING LIGHTING - LIGHTING SECTIONS TECHNICAL SPECIFICATIONS

OPTICAL FEATURES

- Horizontal beam radiation: 360°
- PMMA and tempered glass lens

| ELEVATION | LUMINOUS INTENSITY [cd] | |
|--------------|-------------------------|-----|
| | Min | Max |
| 2° to 12° | 3.5 | 60 |
| > 12° to 20° | 0.5 | 30 |
| > 20° to 90° | 0.2 | 10 |

-180° Azimuth +180°

MECHANICAL FEATURES

- Anodised and painted aluminium body
- EPDM o-ring
- Degree of protection: IP68
- Operating temperature: -20°C to +50°C
- Provided with Luxsolar standard cable 30cm
- Elevation: <25mm
- Tempered glass resistant up to 5000kg load

ELECTRICAL FEATURES

- Powered by LXS control panel:
 - 12/24 or 48 VDC or 115/230 VAC incoming power
 - 24 VDC outgoing power to the beacons
- Power consumption: 2W @24 VDC each element
- Adjustable light intensity: 10% - 30% - 100%
- Failures monitoring

OPTIONS

- IR Wavelength: 850nm, compatible with pilot's NVG
- Available in 1,2,4,5 modules configuration

CERTIFICATIONS

- CE

COMPLIANCE

- ICAO Aerodromes - Annex 14 Volume 2, Heliports
- EASA CS-HPT-DSN
- EASA PTS-VPT-DSN
- CAA CAP1264

ORDER CODE

CRH-LXS-6*

CRH-LXS-3*

* The last code number refers to the possible modules quantity configurations

TECHNICAL DRAWINGS

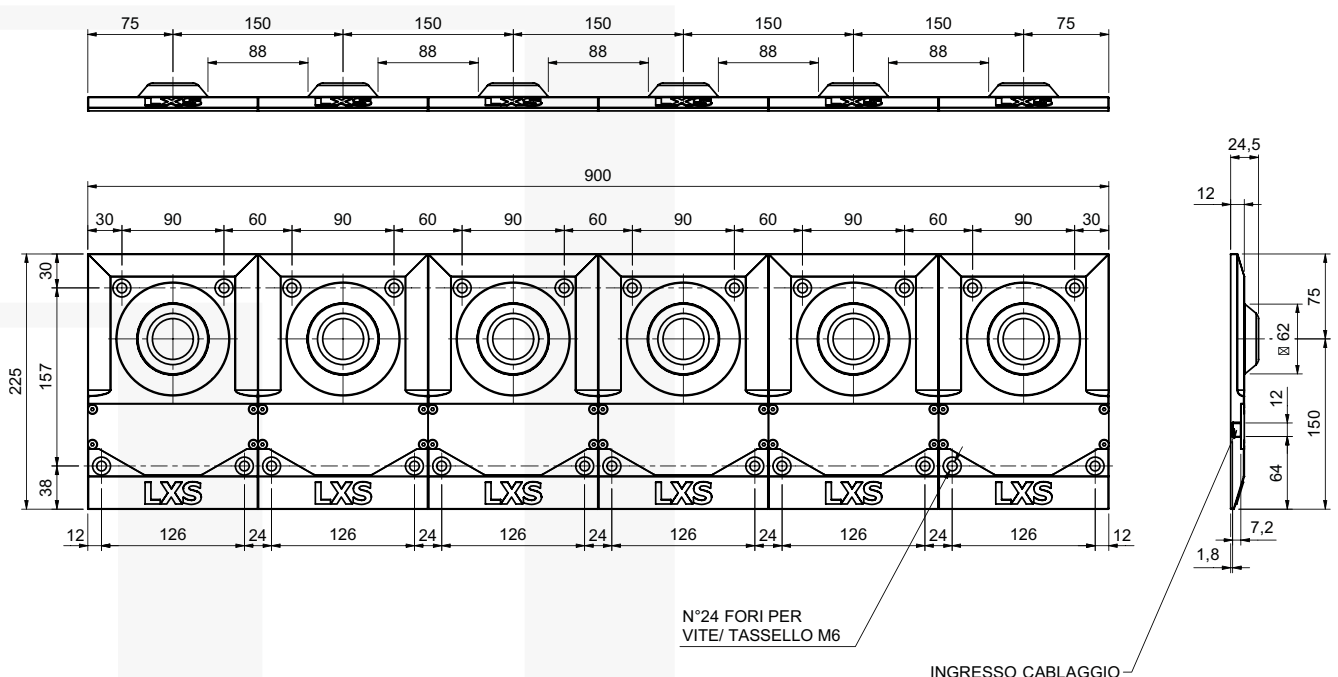

HELIPORT LIGHTS

CROSS CHEVRON LIGHTING - LIGHTING SECTIONS CCH-LXS

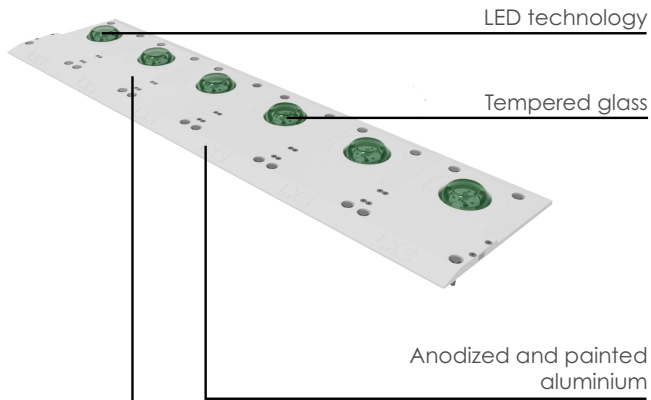

The Cross Chevron Lighting marks the perimeter of the Cross symbol that is central in the TDPC area. The beacon is vehicle-accessible and suitable both for surface and elevated areas.

- Steady GREEN light
- Life time longer than 10 years
- Low consumption
- Stabilised light output
- Light-weight and compact structure
- Easy to install
- No RF-radiations
- IR version available

PATENTED

INSTALLATION MAPS

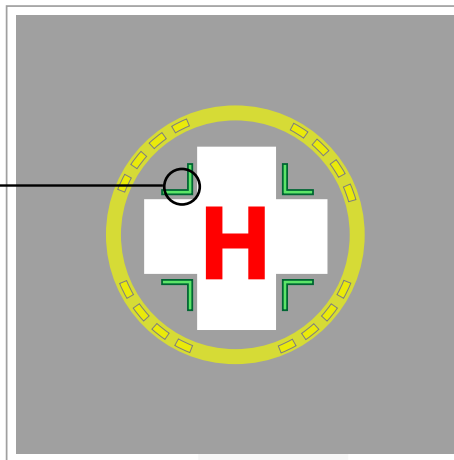

CAPTION

○ CCH-LXS

Quantity of beacons is required by regulation.

CERTIFICATION



COMPLIANCE



FEATURES



HELIPORT LIGHTS

CROSS CHEVRON LIGHTING - LIGHTING SECTIONS TECHNICAL SPECIFICATIONS

OPTICAL FEATURES

- Horizontal beam radiation: 360°
- PMMA and tempered glass lens

| ELEVATION | LUMINOUS INTENSITY [cd] | |
|--------------|-------------------------|-----|
| | Min | Max |
| 2° to 12° | 2 | 30 |
| > 12° to 20° | 0.25 | 15 |
| > 20° to 90° | 0.1 | 5 |

-180° Azimuth +180°

MECHANICAL FEATURES

- Anodised and painted aluminium body
- EPDM o-ring
- Degree of protection: IP68
- Operating temperature: -20°C to +50°C
- Provided with Luxsolar standard cable 30cm
- Elevation: <25mm
- Tempered glass resistant up to 5000kg load

ELECTRICAL FEATURES

- Powered by LXS control panel:
 - 12/24 or 48 VDC or 115/230 VAC incoming power
 - 24 VDC outgoing power to the beacons
- Power consumption: 2W @24Vdc each element
- Adjustable light intensity: 10% - 30% - 100%
- Failures monitoring

OPTIONS

- IR Wavelength: 850nm, compatible with pilot's NVG

CERTIFICATIONS

- CE

COMPLIANCE

- ICAO Aerodromes - Annex 14 Volume 2, Heliports
- EASA CS-HPT-DSN
- EASA PTS-VPT-DSN
- CAA CAP1264

ORDER CODE

CCH-LXS

TECHNICAL DRAWINGS

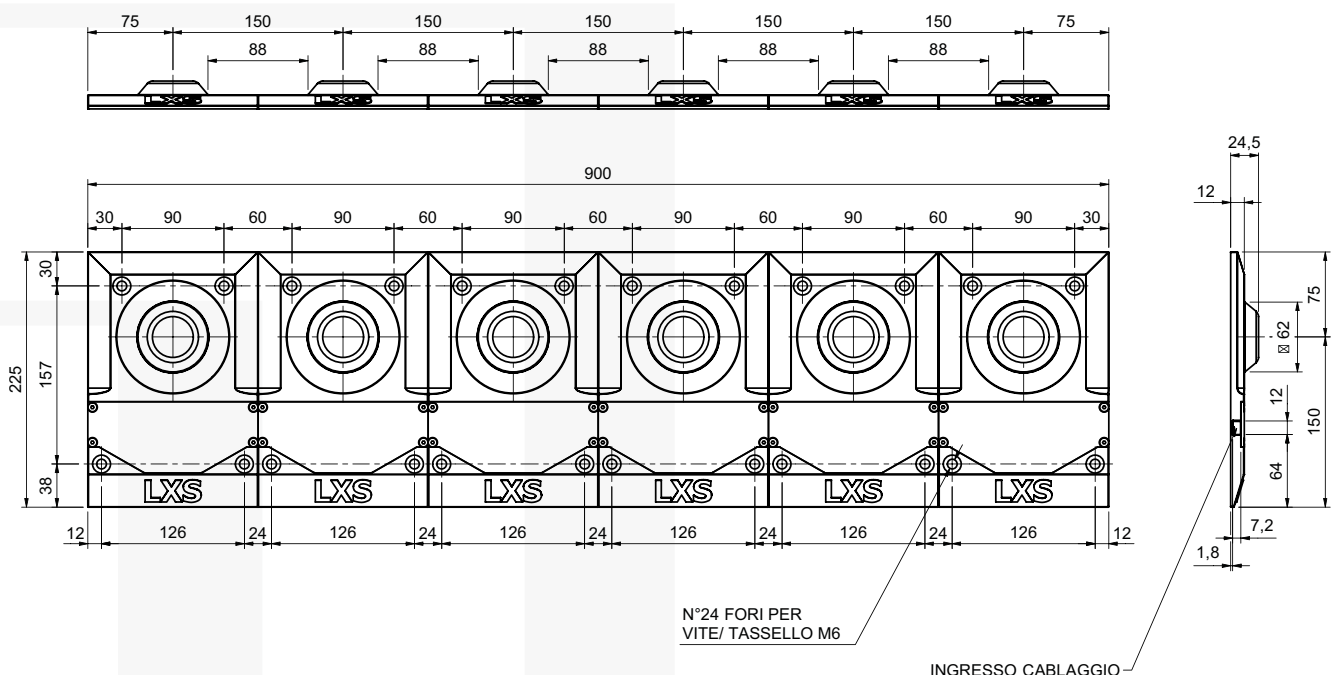

HELIPORT LIGHTS

HELIPORT BEACON - HB HB-LXS

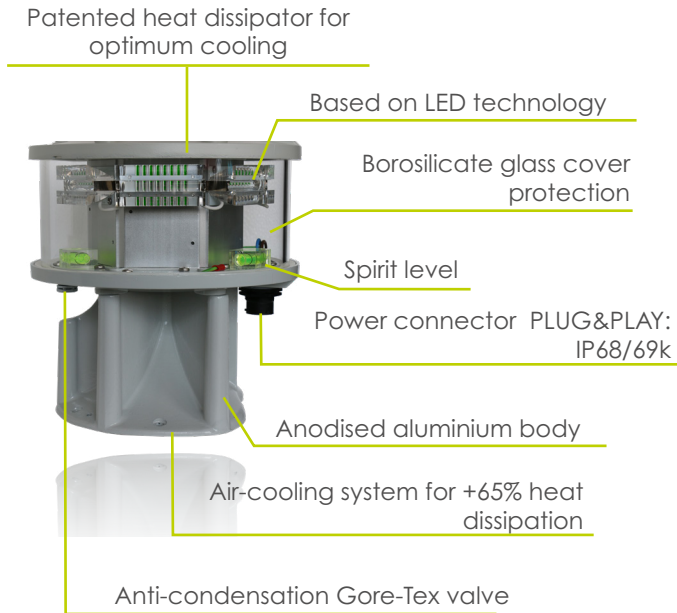

- Long life time >10 years life expectancy
- Morse code "H" White light
- Low consumption
- Stabilised light output
- Lightweight and compact
- Low wind load factor
- Easy to install
- Light output alignment device
- Adjustable intensity OFF -3%, -10%, -100% through external digital switch
- Electronic beacon driver in a separate enclosure

PATENTED

CERTIFICATION



FEATURES

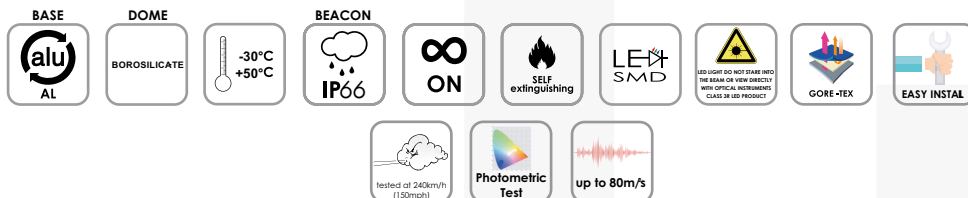

TYPICAL APPLICATION



HELIPORT LIGHTS

HELIPORT BEACON - HB TECHNICAL SPECIFICATION AND DRAWING

OPTICAL FEATURES

- Based on LED technology
- Horizontal beam radiation 360°
- PMMA lens
- Vertical beam spread

| Elevation (E) | Luminous Intensity |
|---------------|--------------------|
| 10° | 250cd |
| 7° | 750cd |
| 4° | 1700cd |
| 2° ½ | 2500cd |
| 1° ½ | 2500cd |
| 0° | 1700cd |

-180° Azimuth +180°

LIGHT MECHANICAL FEATURES

- Anodised aluminium body, painted RAL7035
- Borosilicate glass cover protection
- Silicon rubber, VMQ
- Degree of protection: IP66 (Beacon)
- Operating temperature -30°C to +50°C

CONTROLLER MECHANICAL FEATURES

- Enclosure material: mild steel, painted RAL 7035
- Degree of protection: IP65
- Dimension: 500x300x210mm
- Weight: 20kg
- Operating temperature: -20°C to +50°C

ELECTRICAL FEATURES

- Power supply by LUXSOLAR controller:
 - 12/24 VDC;
 - 115/230 VAC
- Average power consumption 13W
- LED feeded at constant current
- No RF-radiations

CERTIFICATIONS

- ICAO/EASA test report (EN17025 laboratory) nr. 523-QL17-R02
- CE marking

COMPLIANCE

- ICAO Heliports - Annex 14 Vol. II
- ICAO Heliport Manual

ORDER CODE

HB-LXS-IP24
HB-LXS-IP230

HELIPORT LIGHTS

HELIPORT BEACON - HB TECHNICAL SPECIFICATION AND DRAWING

BEACON

FRONT VIEW

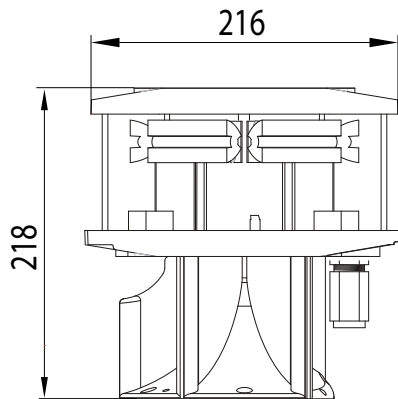

TOP VIEW

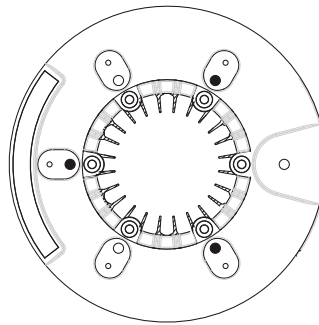

CONTROLLER

FRONT VIEW

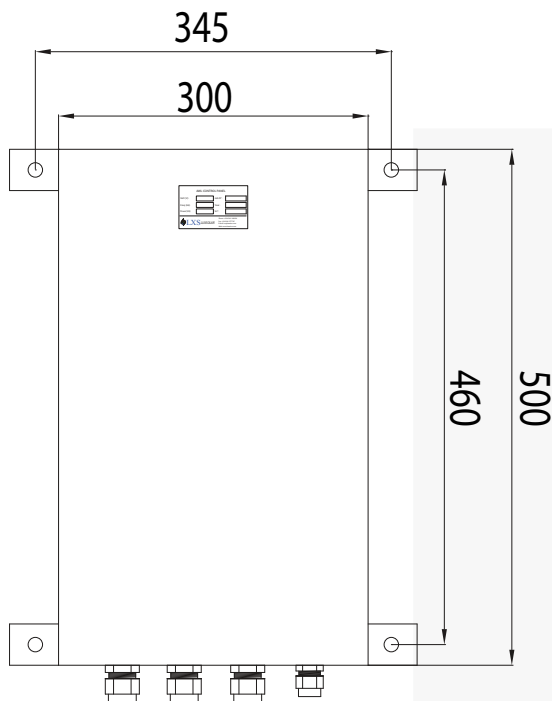

TOP VIEW

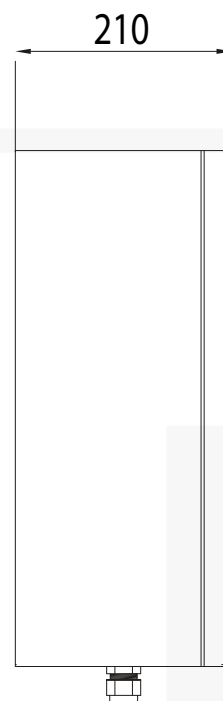

HELIPORT LIGHTS

HELIPORT BEACON - HB TECHNICAL SPECIFICATION AND DRAWING

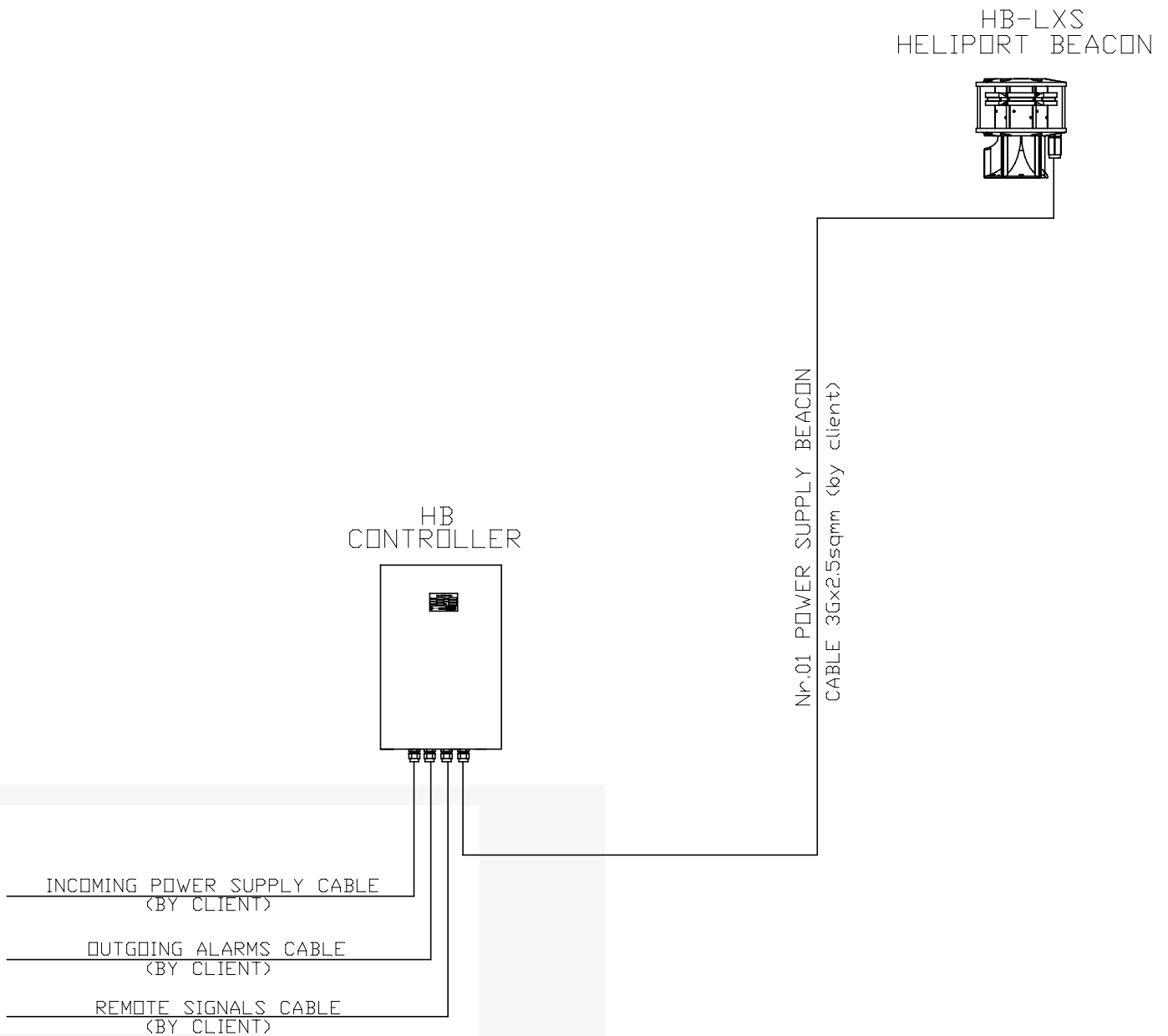

HELIPORT LIGHTS

APPROACH LIGHT - FLASHING LIGHT HAL-LXS-FL

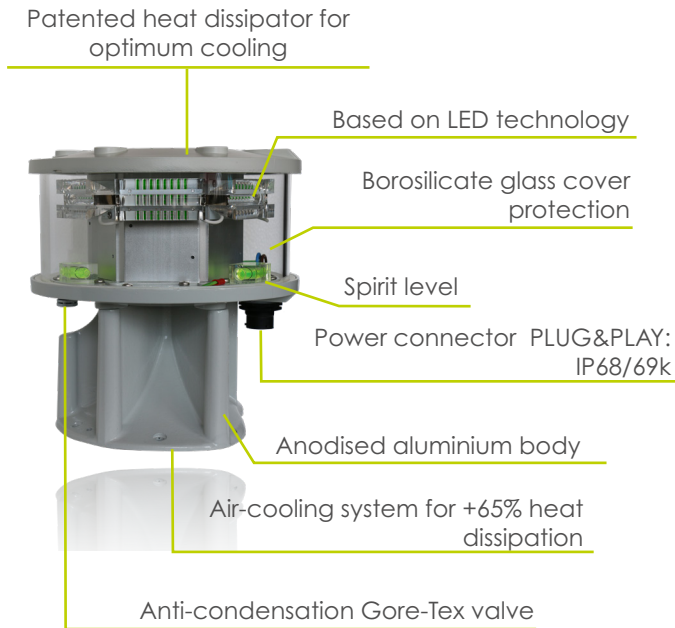

- Long life time **>10 years life** expectancy
- **Flashing WHITE** light
- **Low** consumption
- **Stabilised light** output
- **Lightweight** and **compact**
- **Low** wind load factor
- **Easy** to install
- Light output **alignment device**
- **Adjustable intensity 3%, 10%, 100%** through external digital switch for flashing light
- **Flash sequence starting from the outermost light and progress towards the crossbar**

PATENTED

CERTIFICATION



COMPLIANCE



FEATURES

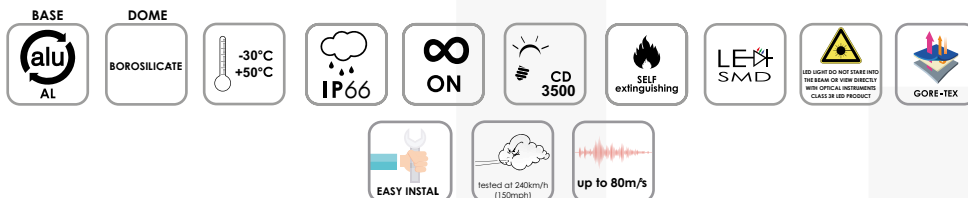

TYPICAL APPLICATION



HELIPORT LIGHTS

APPROACH LIGHT - FLASHING LIGHT TECHNICAL SPECIFICATION AND DRAWING

OPTICAL FEATURES

- Based on LED technology
- Horizontal beam radiation 360°
- PMMA lens
- Vertical beam spread

| Elevation (E) | Luminous Intensity |
|---------------|--------------------|
| 15° | 250cd |
| 9° | 2500cd |
| 6° | 3500cd |
| 5° | 3500cd |
| 2° | 2500cd |
| 0° | 250cd |

-180° Azimuth +180°

LIGHT MECHANICAL FEATURES

- Anodised aluminium body, painted RAL7035
- Borosilicate glass cover protection
- Silicon rubber, VMQ
- Degree of protection: IP66
- Operating temperature -30°C to +50°C
- Weight: 6kg

CONTROLLER MECHANICAL FEATURES

- Enclosure material: mild steel, painted RAL 7035
- Degree of protection: IP65
- Dimension: 500x300x210mm
- Weight: 20kg
- Operating temperature: -20°C to +50°C

ELECTRICAL FEATURES

- Power supply by LUXSOLAR remote controller:
 - 12/24 VDC;
 - 115/230 VAC
- Average power consumption 13W
- LED feeded at constant current
- No RF-radiations

CERTIFICATIONS

- CE marking

COMPLIANCE

- ICAO Heliports - Annex 14 Vol. II
- ICAO Heliport Manual

ORDER CODE

HAL-LXS-FL

HELIPORT LIGHTS

APPROACH LIGHT - FLASHING LIGHT TECHNICAL SPECIFICATION AND DRAWING

BEACON

SIDE VIEW

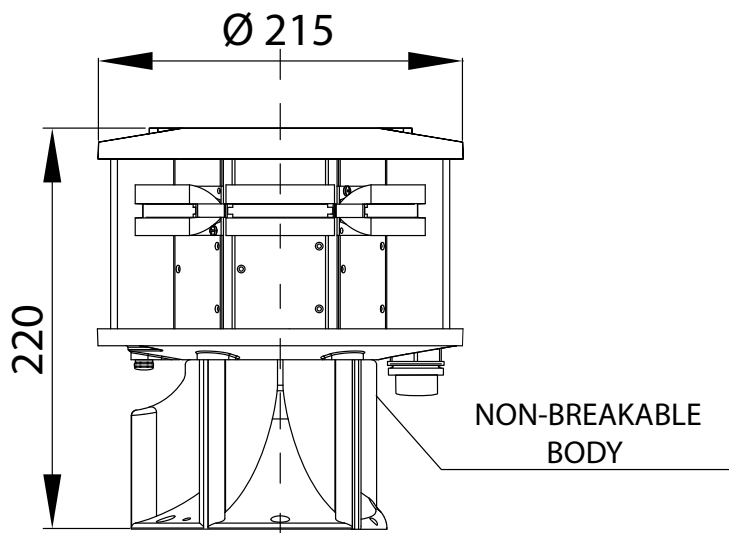

TOP VIEW

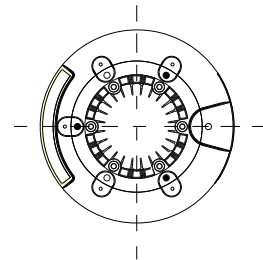

BOTTOM VIEW

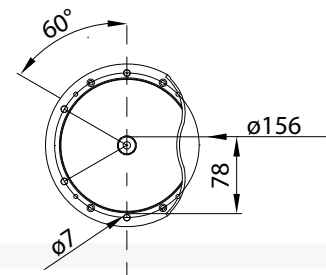

HELIPORT LIGHTS

APPROACH LIGHT - FLASHING LIGHT TECHNICAL SPECIFICATION AND DRAWING

CONTROLLER

FRONT VIEW

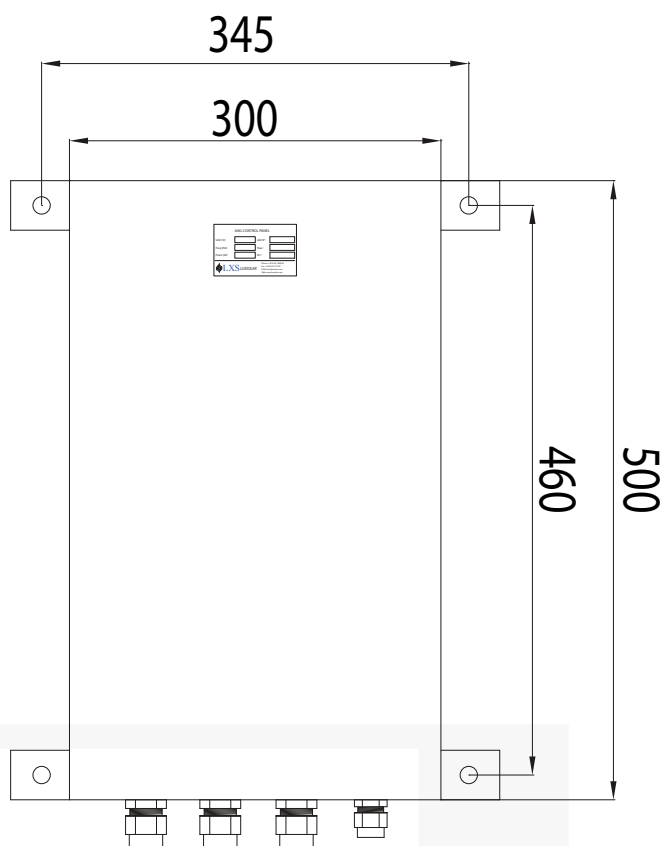

TOP VIEW

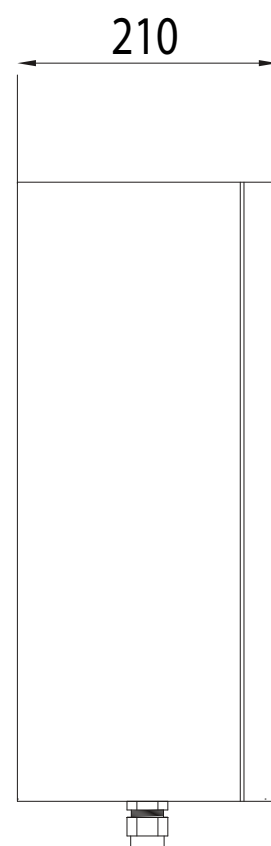

HELIPORT LIGHTS

APPROACH LIGHT - STEADY BURNING HAL-LXS-SB

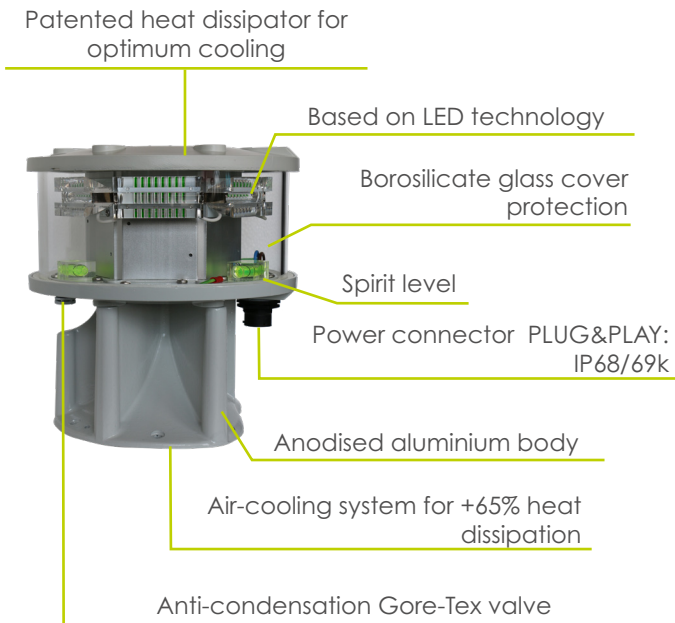

- Long life time **>10 years life** expectancy
- **WHITE steady burning light**
- **Low** consumption
- **Stabilised light** output
- **Lightweight** and **compact**
- **Low** wind load factor
- **Easy** to install
- Light output **alignment device**
- **Adjustable intensity 10%, 30%, 100%** through external digital switch



CERTIFICATION



COMPLIANCE



FEATURES

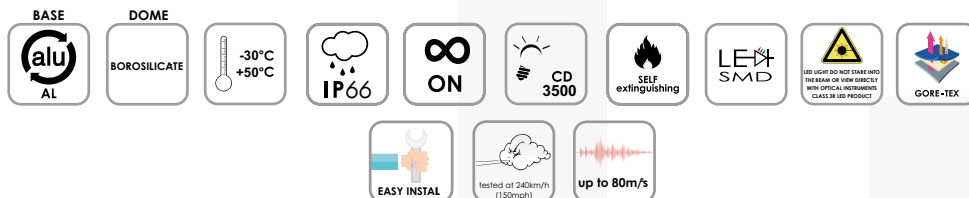

TYPICAL APPLICATION



HELIPORT LIGHTS

APPROACH LIGHT - STEADY BURNING TECHNICAL SPECIFICATION AND DRAWING

OPTICAL FEATURES

- Based on LED technology
- Horizontal beam radiation 360°
- PMMA lens
- Vertical beam spread

| Elevation (E) | Luminous Intensity |
|---------------|--------------------|
| 15° | 25 cd |
| 9° | 250 cd |
| 6° | 350 cd |
| 5° | 350 cd |
| 2° | 250 cd |
| 0° | 25 cd |

-180° Azimuth +180°

LIGHT MECHANICAL FEATURES

- Anodised aluminium body, painted RAL7035
- Borosilicate glass cover protection
- Silicon rubber, VMQ
- Degree of protection: IP66
- Operating temperature -30°C to +50°C
- Weight: 6kg

CONTROLLER MECHANICAL FEATURES

- Enclosure material: mild steel, painted RAL 7035
- Degree of protection: IP65
- Dimension: 500x300x210mm
- Weight: 20kg
- Operating temperature: -20°C to +50°C

ELECTRICAL FEATURES

- Power supply by remote controller:
 - 12/24 VDC;
 - 115/230 VAC
- Average power consumption 13W
- LED fed at constant current
- No RF-radiations

CERTIFICATIONS

- CE marking

COMPLIANCE

- ICAO Heliports - Annex 14, Vol. II
- ICAO Heliport Manual - DOC.9261
- EASA CS-HPT-DSN, Heliports Design

ORDER CODE

HAL-LXS-SB

HELIPORT LIGHTS

APPROACH LIGHT - STEADY BURNING TECHNICAL SPECIFICATION AND DRAWING

BEACON

SIDE VIEW

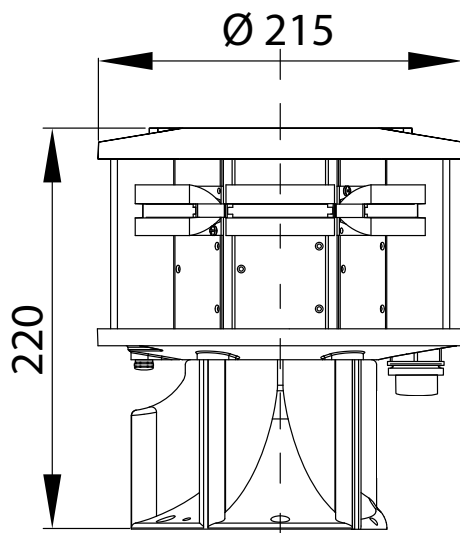

TOP VIEW

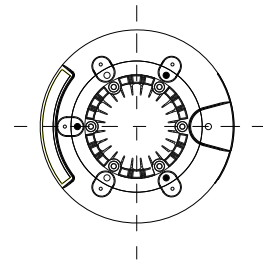

BOTTOM VIEW

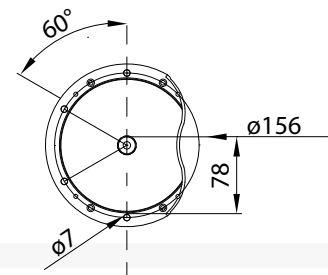

HELIPORT LIGHTS

APPROACH LIGHT - STEADY BURNING TECHNICAL SPECIFICATION AND DRAWING

CONTROLLER

FRONT VIEW

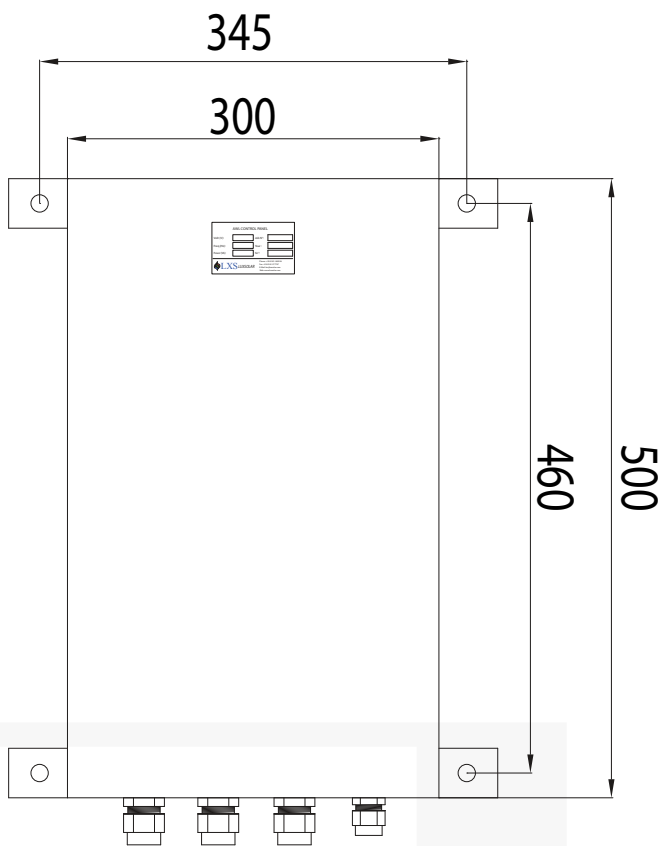

TOP VIEW

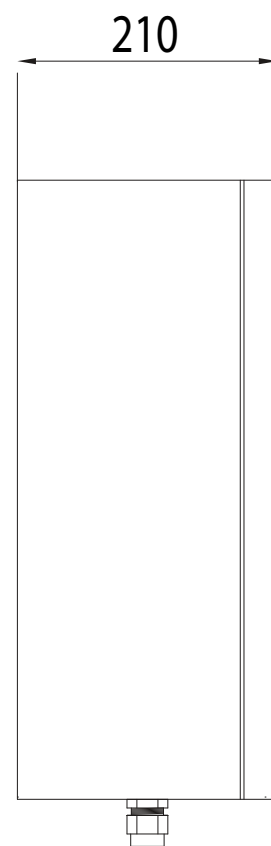

HELIPORT LIGHTS

HELIHOIST STATUS LIGHT HSL-LXS-CAP437-IP

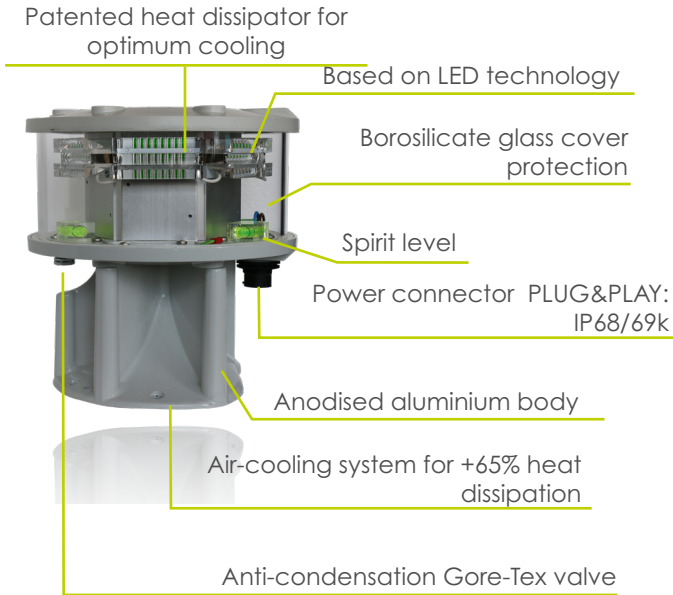

- Light emission:
 - **Green Steady:** wind turbine is secure for operation;
 - **Green Flashing (120fpm):** wind turbine is in preparation to accept hoist operation or during operation parameters are moving out of limits;
 - **Light Off:** wind turbine is not safe for conducting operations;
- Long life time >10 years life expectancy
- Low consumption
- Stabilised light output
- Low wind load factor
- Easy to install
- Light output alignment device

PATENTED



CERTIFICATION



COMPLIANCE



FEATURES



TYPICAL APPLICATION



HELIPORT LIGHTS

HELIHOIST STATUS LIGHT TECHNICAL SPECIFICATION AND DRAWING

OPTICAL FEATURES

- Horizontal beam radiation 360°
- PMMA lens
- Vertical beam radiation:

| | Min. Intensity | | Max. Intensity | |
|-------|----------------|-------------|----------------|-------------|
| | 2° to 10° | >10° to 90° | 0° to 15° | >15° to 90° |
| Day | 410cd | 16cd | 750cd | 120cd |
| Night | 16cd | 3cd | 60cd | 60cd |

LIGHT MECHANICAL FEATURES

- Anodised aluminium body, painted RAL7035
- Borosilicate glass cover protection
- Silicon rubber, VMQ
- Degree of protection: IP66 (Beacon)
- Operating temperature -30°C to +50°C

CONTROLLER MECHANICAL FEATURES

- Enclosure material: mild steel, painted RAL 7035
- Degree of protection: IP65
- Dimension: 500x300x210mm
- Weight: 20kg
- Operating temperature: -20°C to +50°C

APPLY TO

- Offshore heliport platforms, located on the nacelle and used to indicate to pilot the status (safe or unsafe) of the wind turbine before commencing of any hoist operation

CERTIFICATIONS

- CE marking

COMPLIANCE

- CAP437 "Standard for offshore Helicopter donating Areas" Ch. 10 and Appendix J
- CAP437 "Policy and guidelines on wind turbines", Ch. 4

ORDER CODE

HSL-LXS-CAP437-IP

HELIPORT LIGHTS

HELIHOIST STATUS LIGHT TECHNICAL SPECIFICATION AND DRAWING

BEACON

FRONT VIEW

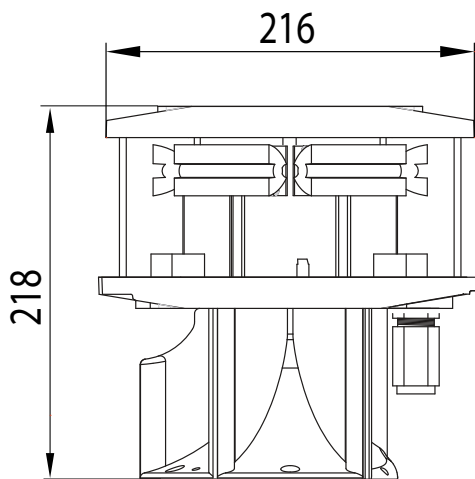

TOP VIEW

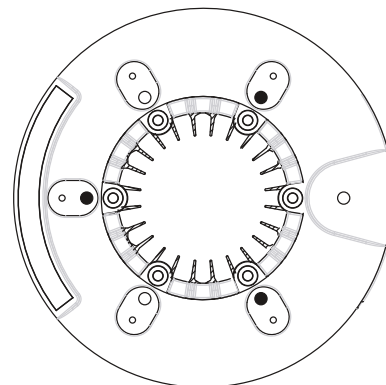

HELIPORT LIGHTS

HELIHOIST STATUS LIGHT TECHNICAL SPECIFICATION AND DRAWING

CONTROLLER

FRONT VIEW

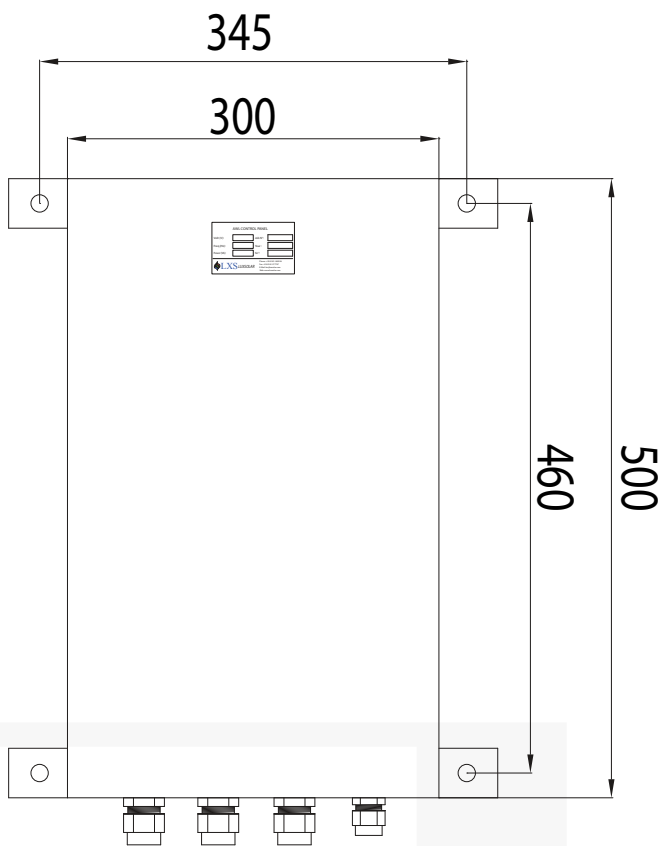

TOP VIEW

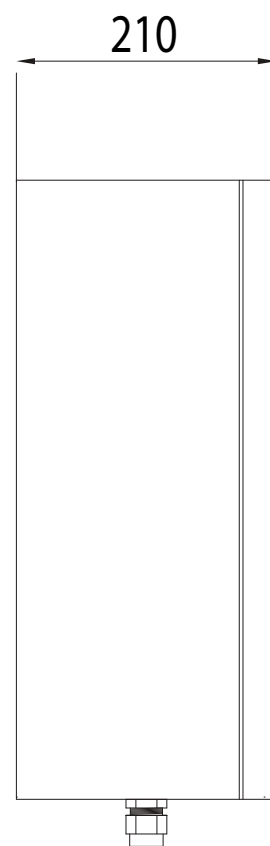

HELIPORT LIGHTS

LXS HELIPORT LIGHTED WINDSOCK

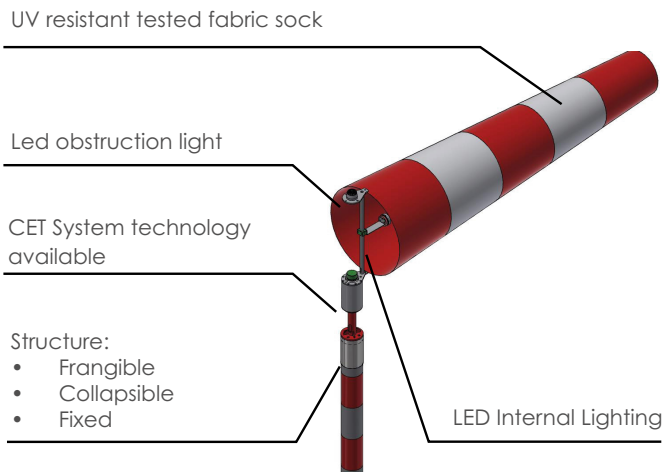

The internal lights of the sock and the obstruction light are powered by the innovative CET (Contactless Energy Transmission) system, for the wireless transfer of energy from the fixed to the mobile rotating part of the sock.

- Contactless power supply available
- Internal and external lighting compliant to regulations



TECHNICAL SPECIFICATIONS

SOCK FEATURES

- Colour:
 - Unicolour Red
 - Unicolour Orange
 - Unicolour White
 - Two-tone Red and White
- Material: Polyester or Nylon
- Throat opening: from $\varnothing 250\text{mm}$ to $\varnothing 900\text{mm}$
- Length: according to throat diameter
 - Designed to be visible up to 200m distance
 - 360° complete rotation

MECHANICAL FEATURES

- Pole material:
 - Aluminium
 - Glass Reinforced Polyester (GRP)
 - Stainless Steel
- Windsock height: from 2m to 6m
- Pole structure type:
 - Fixed
 - Frangible
 - Collapsible
 - Frangible + Collapsible
- Sock frame material: Stainless Steel
- Degree of protection: IP66

ELECTRICAL FEATURES

- Power supply: 24VDC or 230 Vac
- Power consumption: 20W
- LED fed at constant current
- CET (Contactless Energy Transmission) available

OBSTRUCTION LIGHT OPTICAL FEATURES

- Horizontal emission: 360°
- Vertical emission: as per ICAO rule L810 Type A or Type B

WINDSOCK OPTIONS

- Pole painting
- Power supply 110/220 Vac
- IR light compatible with NVG
- Lower temperature compatibility (-50°C)

TEMPERATURE

- Operating temperature: -20°C to +50°C

COMPLIANCE

- ICAO Annex 14 Vol. II Heliports - par. 5.1.1
- ICAO Annex 14 Vol. I Visual Aids - par. 5.1.1
- FAA AC 150 / 5345 - 27
- EASA Chapter F - Heliport Windsock Visual Aids
- PTS - VPT - DSN EASA

HELIPORT LIGHTS

LXS HELIPORT LIGHTED WINDSOCK PRODUCT CONFIGURATION

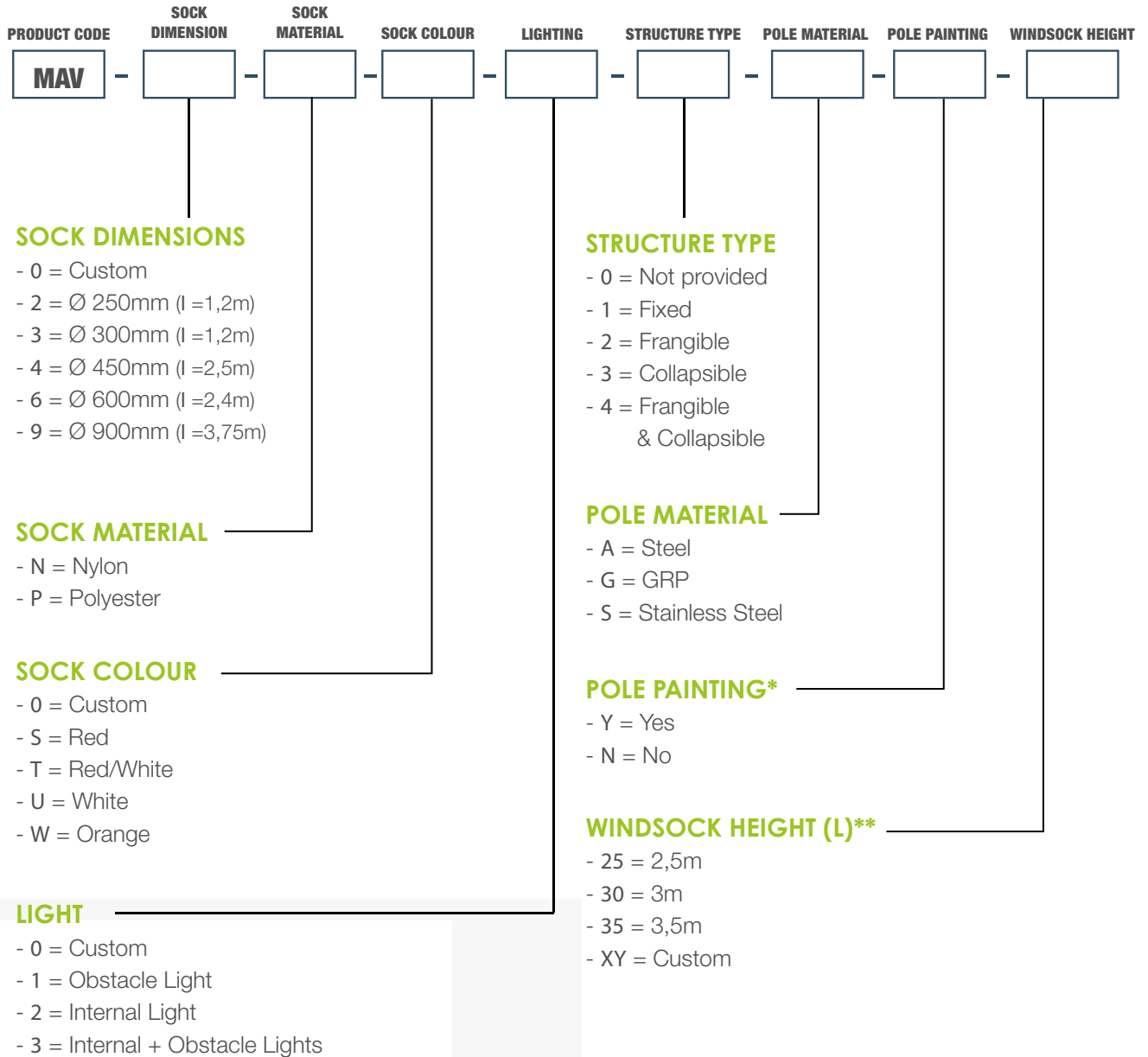

*Painted with red/white alternate bands

** To wind sock centerline

HELIPORT LIGHTS

LXS HELIPORT LIGHTED WINDSOCK STRUCTURE TYPE

GRP

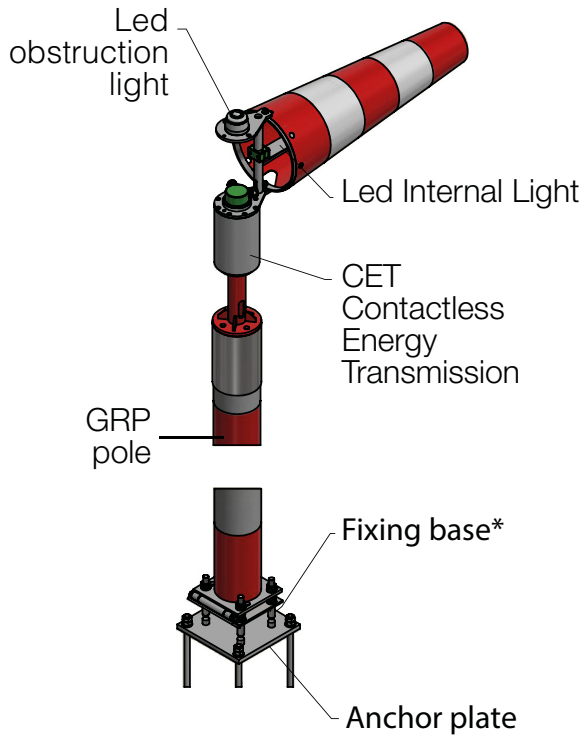

1) Frangible*

Frangibility, in case of impact, 4 specially design frangible bolts will bring the entire structure down to the ground.



2) Collapsible*

The structure can be can be overturned at ground level by means of a hinge for maintenance and checks.



3) Frangible + Collapsible*

Commbination of hinge and frangible bolts improves the global safety of the system.

STEEL

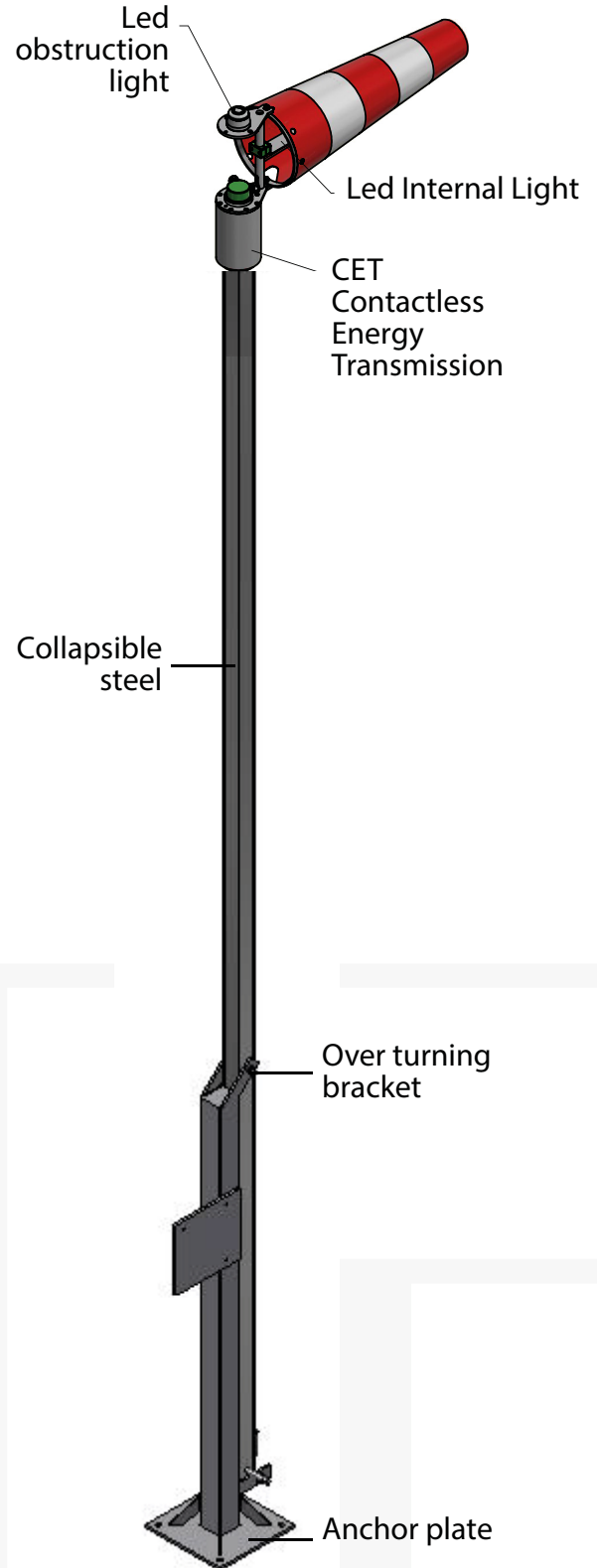

HELIPORT LIGHTS

LXS HELIPORT LIGHTED WINDSOCK LIGHTING COMPARISON



Style I-A



Externally lighted:

External Lighting with projectors placed over the windsock, in a way that the sock is lighted in all positions.

This solution needs a lot of power.

Style I-B



Internally lighted:

1) Internal lighting by reflectors chasing the windsock.

The reflector reduces the wind flow, necessary to inflate the sock. The problem is significant in medium and bigger sized windsocks.

Luxsolar® solution.



Style I-C



Internally lighted:

2) This solution has the advantage to illuminate only the sock from the inside, avoiding unnecessary energy consumption. The lamp illuminates the sock from the inside. The power is transferred from the fixed part to the mobile basket through an innovative Contactless Energy Transmission - CET.

Luxsolar® solution.



HELIPORT LIGHTS

HELIPORT FLOODLIGHT HFL-LXS-10K

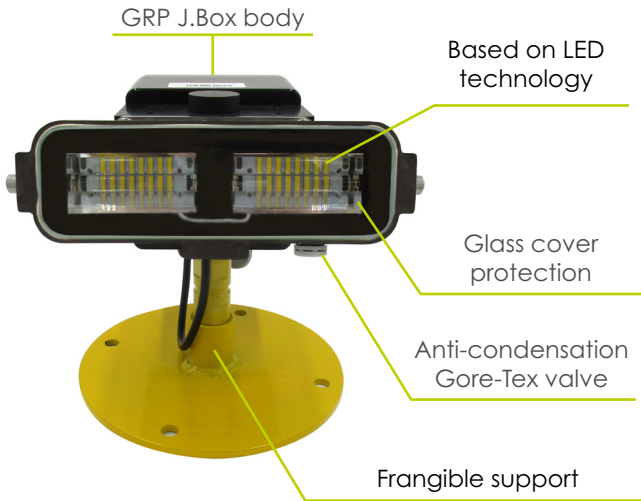

- Long life time **>10 years life** expectancy
- **10.000cd, WHITE** steady burning
- Light emission **angle adjustable**
- **Easy** to install



HELIPORT FLOODLIGHT (night)
HFL-LXS-10K

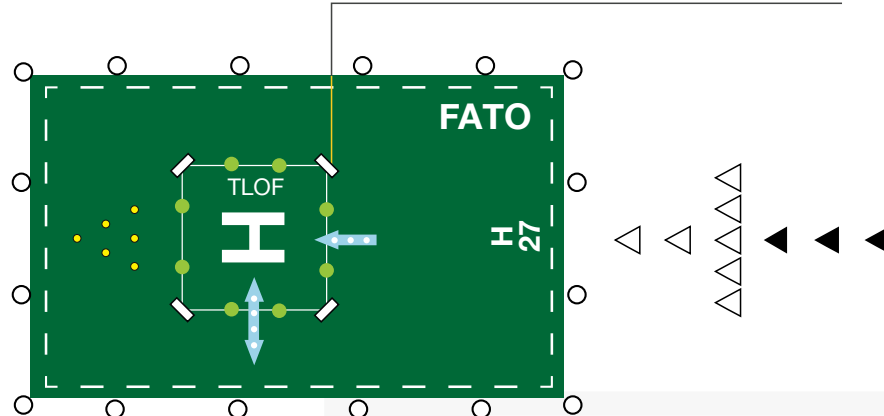

CERTIFICATION



COMPLIANCE



FEATURES



TYPICAL APPLICATION



HELIPORT LIGHTS

HELIPORT FLOODLIGHT TECHNICAL SPECIFICATION AND DRAWING

OPTICAL FEATURES

- Horizontal light emission: 60°
- Vertical light emission: as per ICAO rule

MECHANICAL FEATURES

- Aluminium body c/w frangible support
- Degree of protection: IP66
- Operating temperature: -20°C to +60°C
- Cover: borosilicate

ELECTRICAL FEATURES

- Power consumption: 24W
- Power supply:
12/24 Vdc or 110/230VAC 50/60Hz

APPLY TO

- Heliport

CERTIFICATIONS

- CE marking

COMPLIANCE

- ICAO, Annex 14, Vol. II, "Heliports"
- ICAO Heliport Manual
- ENAC, regulation "Costruzione ed esercizio degli eliporti"
- CAP437 "Standards for offshore helicopter landing areas"

ORDER CODE

HFL-LXS-10K

SIDE VIEW

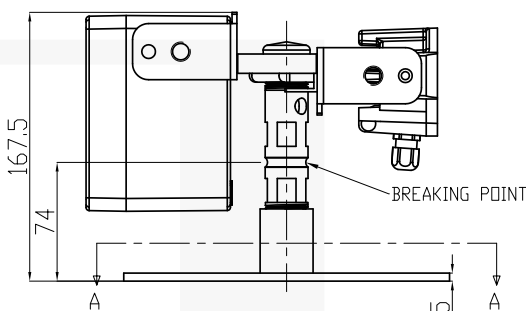

TOP VIEW

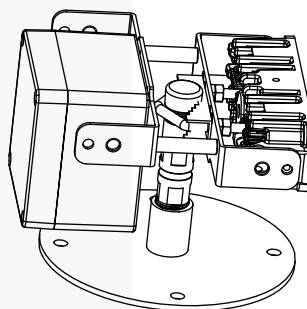

BOTTOM VIEW

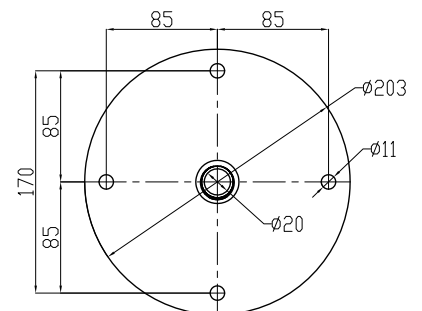

HELIPORT LIGHTS

HELIPORT FLOODLIGHT TECHNICAL DIAGRAMS

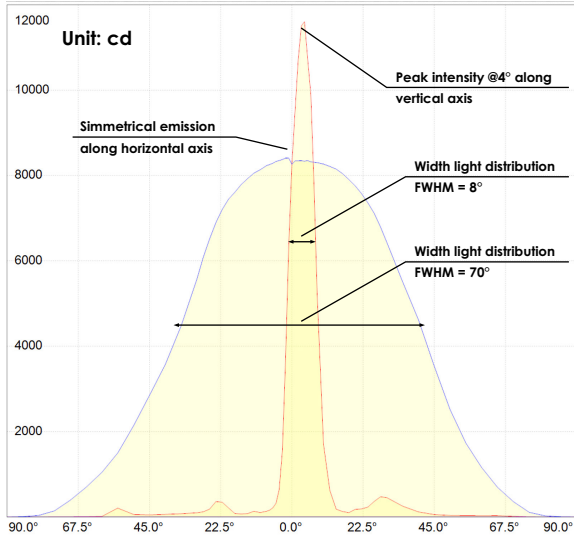

Cartesian Diagram

— C90 - C270
— C0 - C180

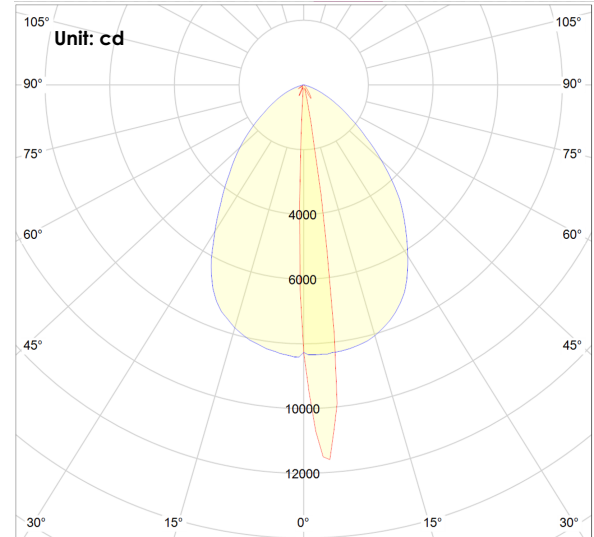

Polar Diagram

— C90 - C270
— C0 - C180

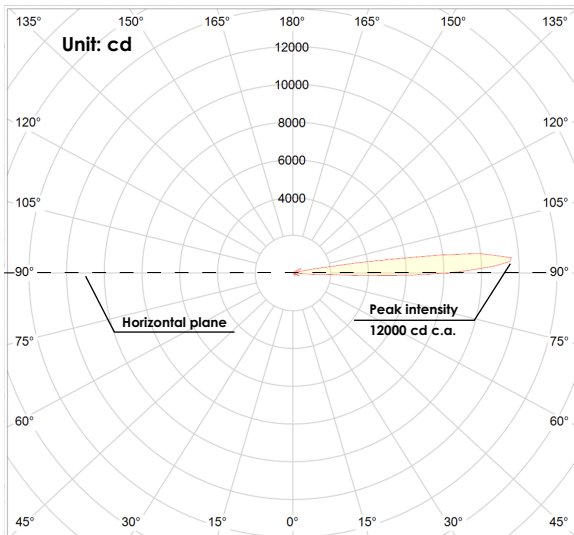

Polar Diagram

— C0 - C180

C-planes are used in photometric curves in order to completely describe a photometric solid.

They are section planes which have in common the optical axis of the light source and are classified by the letter C followed by the rotation angle with respect to the reference plane.

So, C0-C180 and C90-C270 are orthogonal planes to each other and in particular plane C0-C180 is referred to the horizontal direction while plane C90-C270 is referred to the vertical direction.

HELIPORT LIGHTS

HELIDECK MONITORING SYSTEM REPEATER STATUS LIGHTS for Safe Area applications - Unclassified

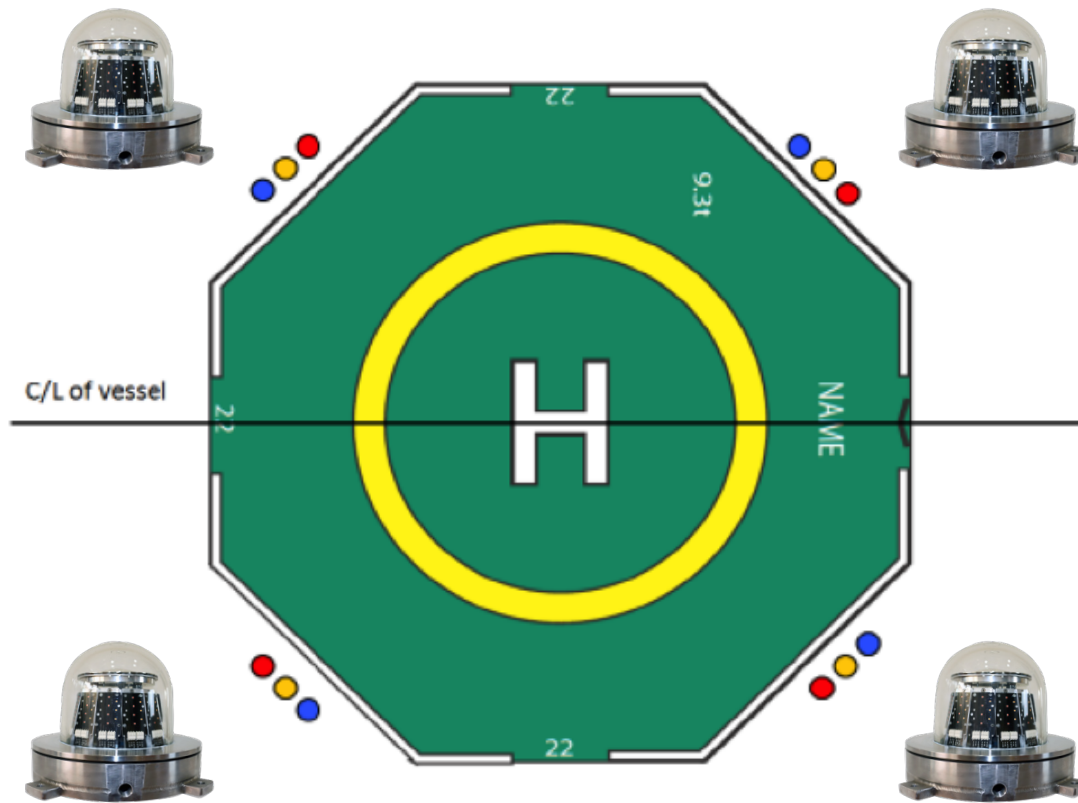

According to **CAP437 "Standards for Offshore Helicopter Landing Areas" 8th Edition**, from 1st April 2021 all moving helidecks must be provided with a **Helideck Monitoring System compliant with Rev.9 or later of the standard published on the Helideck Certification Agency's website.**

The Helideck Monitoring System provides information on helideck movement and includes a helideck mounted light signalling system. **This system indicates the motion status of the helideck directly to pilots prior to landing, and provides warnings of any deterioration in conditions after landing.**

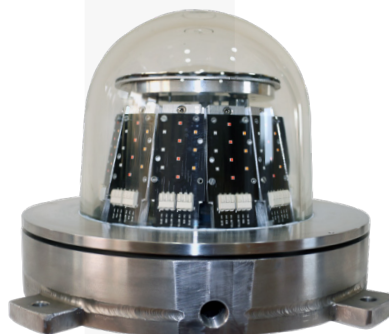

HELIPORT LIGHTS

REPEATER STATUS LIGHT

Tempered glass dome

Light specifically designed to comply with UK standards



Terminal box

<150mm light elevation from helideck surface

IP66

LUXSOLAR HMS-LXS-Ex Helideck Monitoring Light System is realized as **fully in compliance with Standard Helideck Monitoring Systems and CAP437 standards.**

With a **compact body high quality materials for maximum resistance to salt-atmosphere** during the years, **high quality and ultra-bright LEDs**, customized lenses for optimum light emission, **LUXSOLAR HMS-LXS beacons are the most up-to-dated and technologically advanced lighting system for Helideck operations.**

The system comes with a **dedicated LUXSOLAR control panel that can be provided suitable for safe or hazardous area, easy and quick to install and connect to helideck Motion Monitoring System for an high performance and safe lighting system.**

CERTIFICATION



FEATURES



TYPICAL APPLICATION



HELIPORT LIGHTS

REPEATER STATUS LIGHT TECHNICAL SPECIFICATION

OPTICAL FEATURES

- Based on LED technology
- AMBER/RED/BLUE light in one light fixture
- FLASHING/STEADY burning mode as per CAP437
- Horizontal beam radiation: 360°
- Vertical beam spread: as per CAAi rule

LIGHT MECHANICAL FEATURES

- Marine grade aluminum, painted RAL7035 (as option SS316L body material, natural finish)
- SS316L fixing bracket, natural finish
- Borosilicate glass cover protection
- Degree of protection: IP66
- Ambient temperature: -50°C to +60°C
- Lamp unit weight: 19Kg

PANEL MECHANICAL and ELECTRICAL FEATURES

Common features:

- Complete with LUXSOLAR electronic components for HMS Repeater System operation
- Complete with 3 contacts to connect to helideck's Helideck Monitoring System (HMS)
- Power consumption for HMS Repeater Light LUXSOLAR system (4HMS lights + 1 Control Panel): 300W approx

Specific features for Safe Area Control Panel:

- Available in carbon steel (painted RAL7035) or SS316L (natural finish) material
- Ambient temperature: -20°C to +50°C

Specific features for Hazardous Area Control Panel:

- Available in SS316L (natural finish) or aluminium (painted RAL7035) material
- Ambient temperature: -50°C to +50°C

ORDER CODE

HMS-LXS-IP- 1 2

Number of lights per system = N

IP = Panel suitable for safe area
Ex = Panel suitable for hazardous area

APPLY TO

- Vessel
- Floating Production Unit
- Semi-Submersible Rig
- Floating Jack Up Rig
- Any other moving helideck

COMPLIANCE

- CAP437 - Standards for Offshore Helicopter Landing Area
- Standard Measuring Equipment for Helideck Monitoring System (HMS) and Weather Data

CERTIFICATION

- Statement of Compliance issued by CAAi

ORDER CODE

HLW-LXS-IP

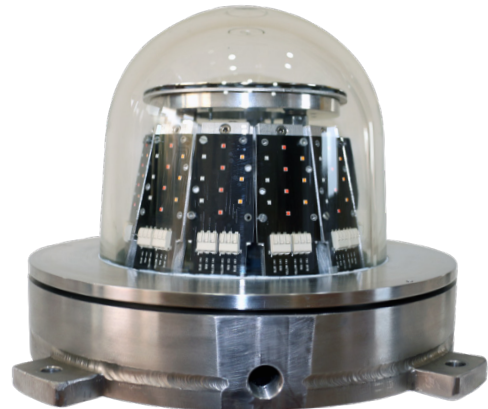

HELIPORT LIGHTS

REPEATER STATUS LIGHT LIGHT DISTRIBUTION STEADY

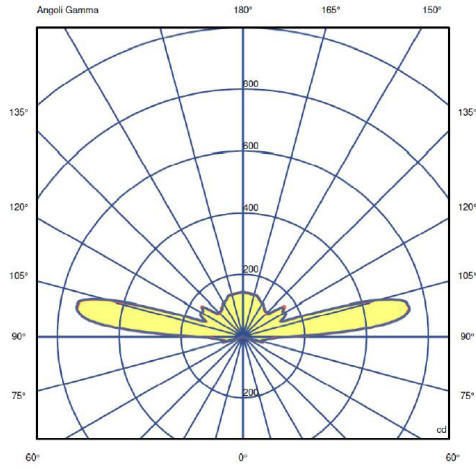

Amber Light DAY

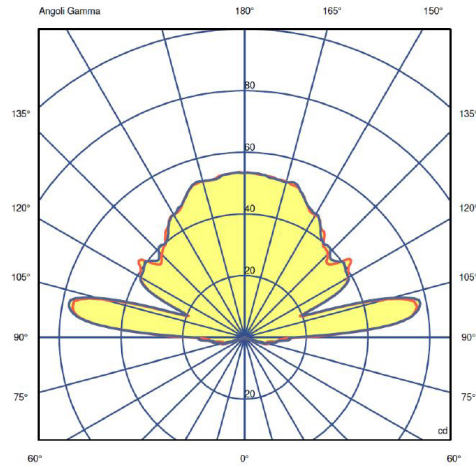

Amber Light NIGHT

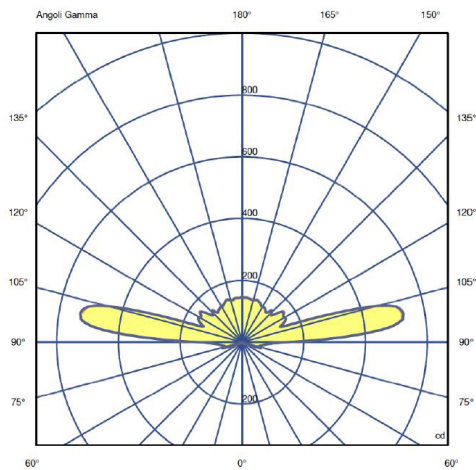

Red Light DAY

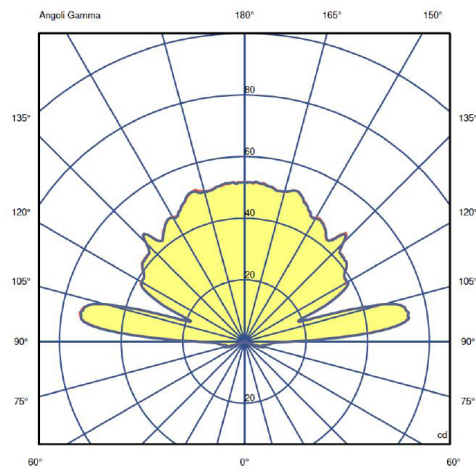

Red Light NIGHT

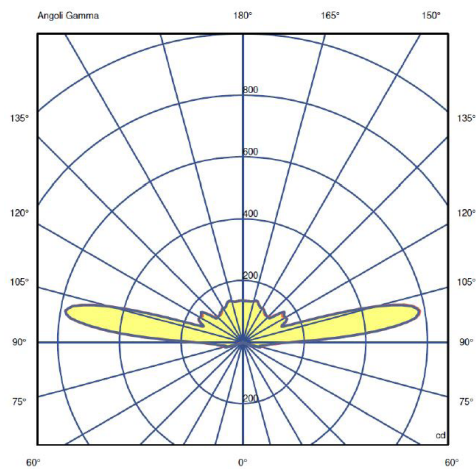

Blue Light DAY

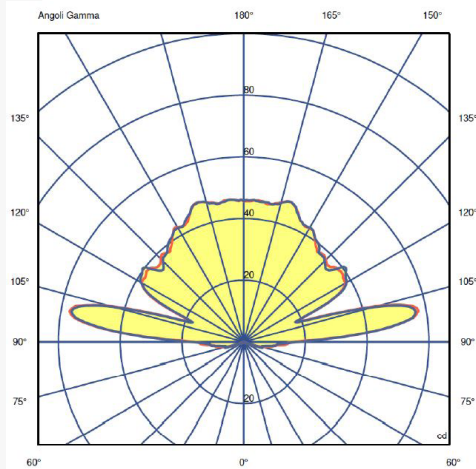

Blue Light NIGHT

HELIPORT LIGHTS

REPEATER STATUS LIGHT LIGHT DISTRIBUTION FLASHING

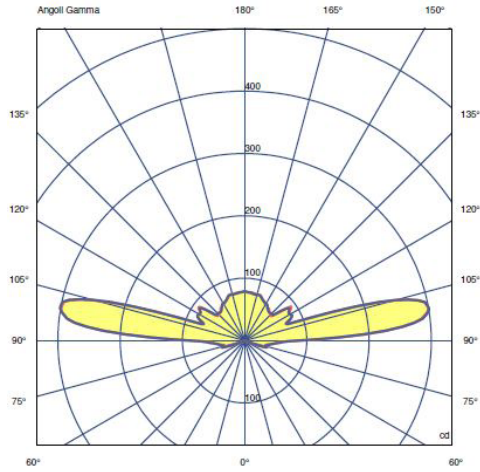

Amber Light DAY

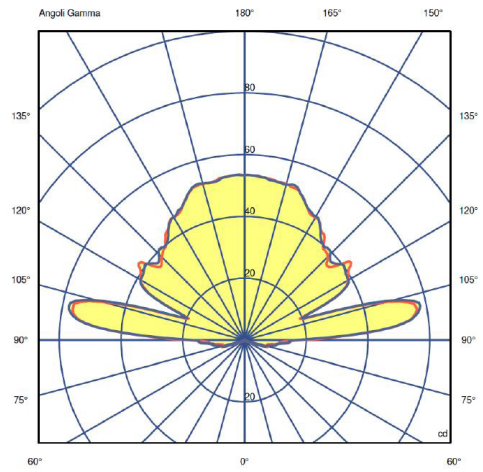

Amber Light NIGHT

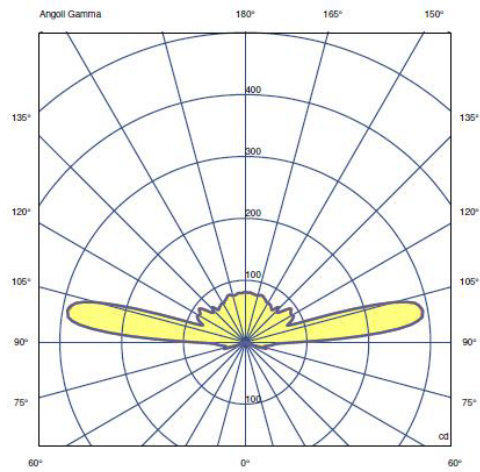

Red Light DAY

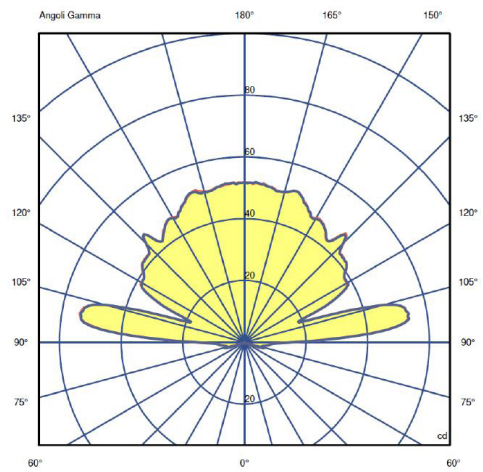

Red Light NIGHT

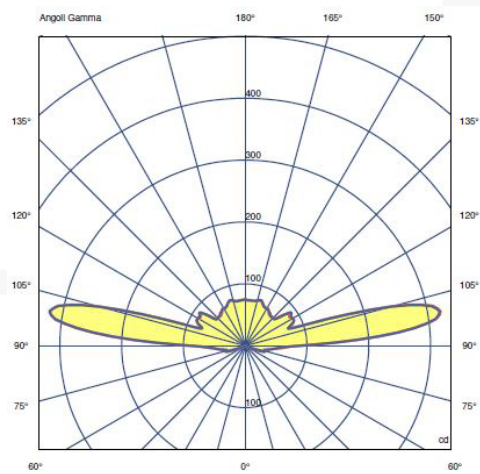

Blue Light DAY

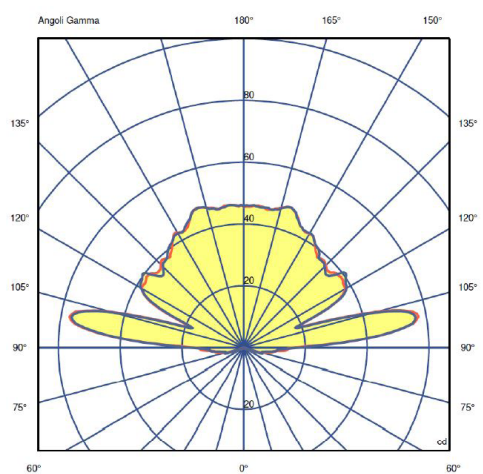

Blue Light NIGHT

HELIPORT LIGHTS

REPEATER STATUS LIGHT TECHNICAL DRAWINGS

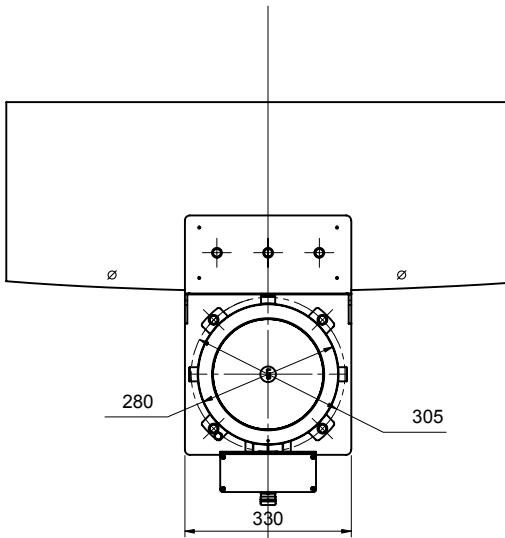
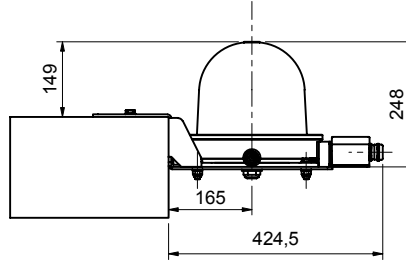
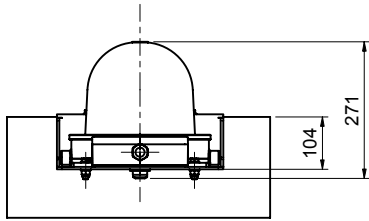

LATERAL FIXING

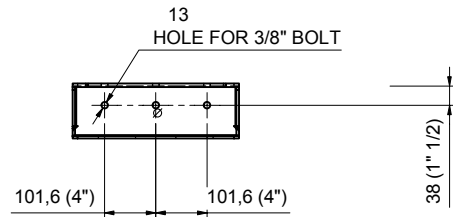

TOP FIXING

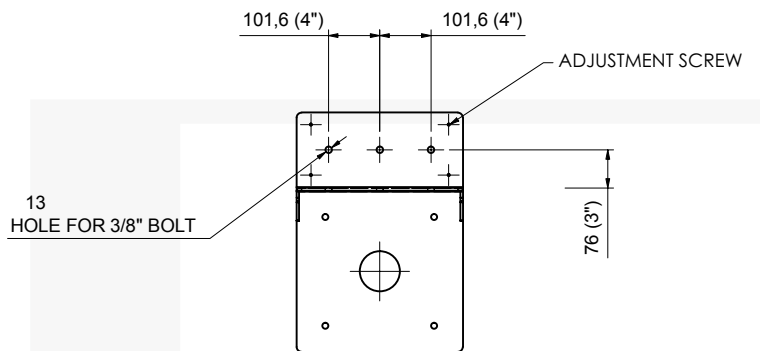

HELIPORT LIGHTS

REPEATER STATUS LIGHT TECHNICAL DRAWINGS

TYPICAL CONFIGURATION HAZARDOUS AREA PANEL

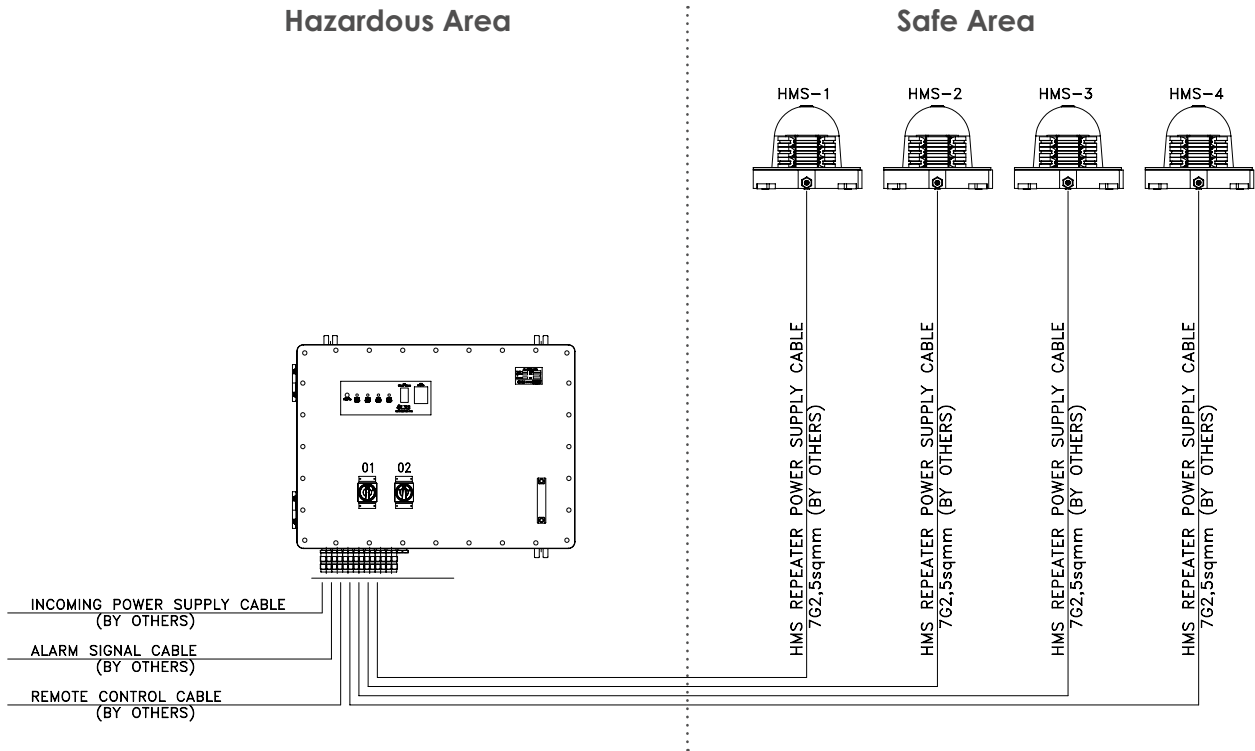

TYPICAL CONFIGURATION SAFE AREA

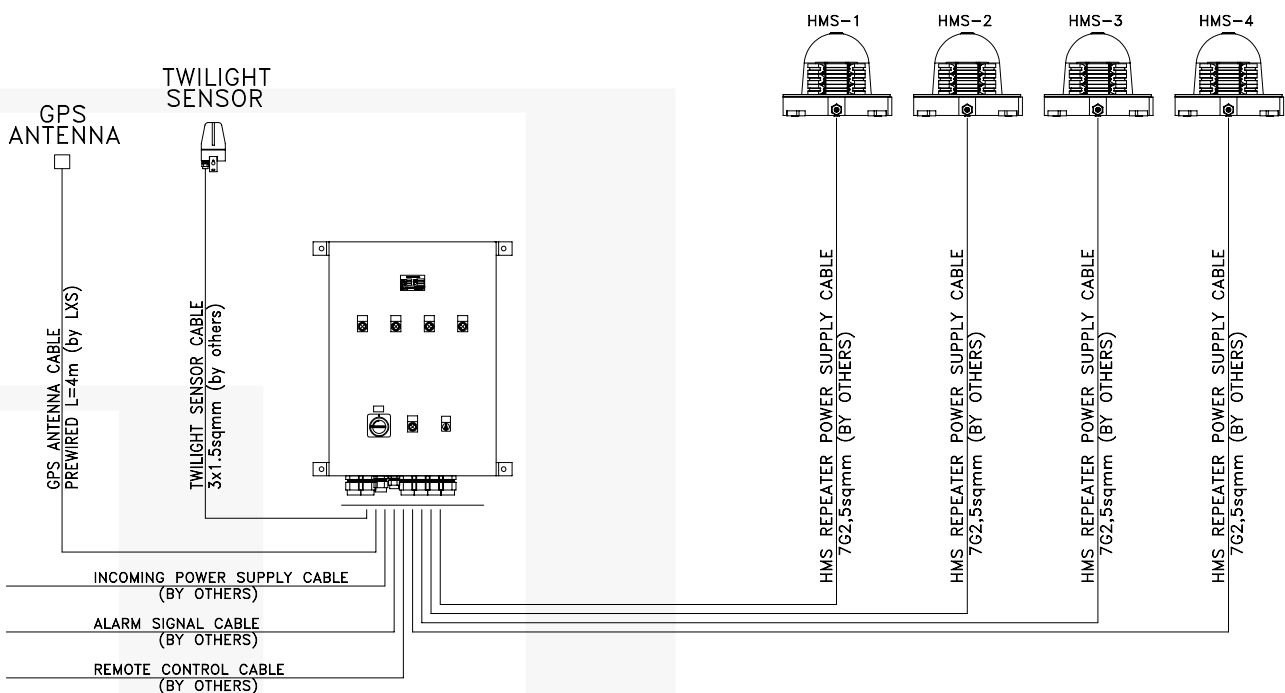

HELIPORT LIGHTS

LXS PORTABLE LIGHTING SYSTEM LXS-RESCUE



PATENTED

During **emergencies**, helipads where night operations are authorized become a crucial infrastructure. To cope with this need, Luxsolar R&D team has developed a **portable lighting system**.

Such lights create a temporary helipad perimeter landing area, allowing helicopters to operate safely.

LXS-Rescue is a versatile product: it can be used in several situations and operated by non-technical personnel, such as police force, emergency and rescue teams, highways employers, service areas employers, etc.

SUGGESTED CONFIGURATION

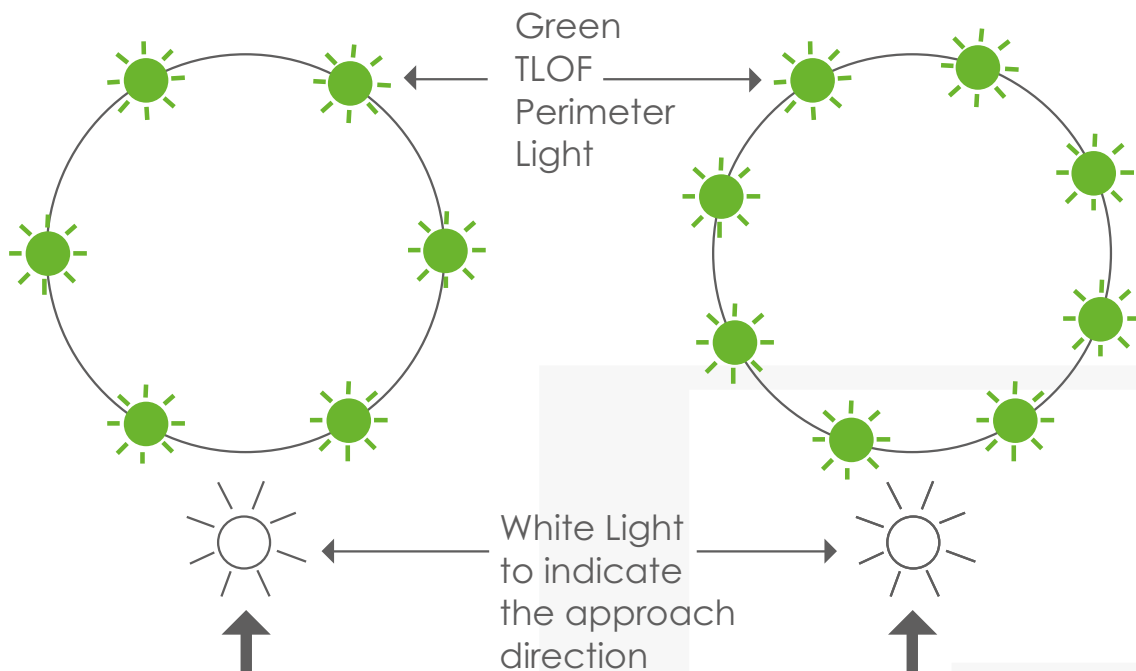

COMPLIANCE



FEATURES



HELIPORT LIGHTS

LXS PORTABLE LIGHTING SYSTEM TECHNICAL SPECIFICATIONS

OPTICAL FEATURES

- Horizontal beam radiation: 360°
- PC lenses
- FATO perimeter light (white)

| Elevation (E) | Luminous Intensity [cd] |
|---------------|-------------------------|
| 30° | 10 |
| 20° | 50 |
| 20° | 100 |
| 10° | |
| 3° | |
| 0° | 10 |

-180° Azimuth +180°

- TLOF perimeter light (green)

| Elevation (E) | Luminous Intensity [cd] |
|---------------|-------------------------|
| 20° < E ≤ 90° | 3 |
| 13° < E ≤ 20° | 8 |
| 10° < E ≤ 13° | 15 |
| 5° < E ≤ 10° | 30 |
| 2° < E ≤ 5° | 15 |

-180° Azimuth +180°

MECHANICAL FEATURES

- Light body: GRP
- NBR O-RING
- Degree of protection: IP68
- Operating temperature: -30°C to +60°C
- Light weight: 1Kg approx
- Trolley housing body: PP + Nylon
- System total weight < 20kg

ELECTRICAL FEATURES

- Light power supply: battery LI-ION
- Wireless recharging system
- Housing power supply: 115/230 Vac through dedicated cable
- Light intensity adjustable: 50% - 100%
- Autonomy: up to 100 hours
- Twilight sensor
- Switch for on/off and adjust light intensity

OPTIONS

- IR Wavelength: 850nm, compatible with pilot's NVG
- 7 lights system or 9 lights system
- Lights available in 5 colors:
 - ● Green light
 - ○ White light
 - ● Red light
 - ● Yellow light
 - ● Blue light

COMPLIANCE

- ICAO Aerodromes- Annex 14, Volume 2, Heliports
- EASA CS-HPT-DSN
- Trolley: STANAG, DEF STAN and NATO approved

PART NUMBER

LXS-RESCUE

HELIPORT LIGHTS

LXS PORTABLE LIGHTING SYSTEM TECHNICAL DRAWING

7 LIGHTS VERSION

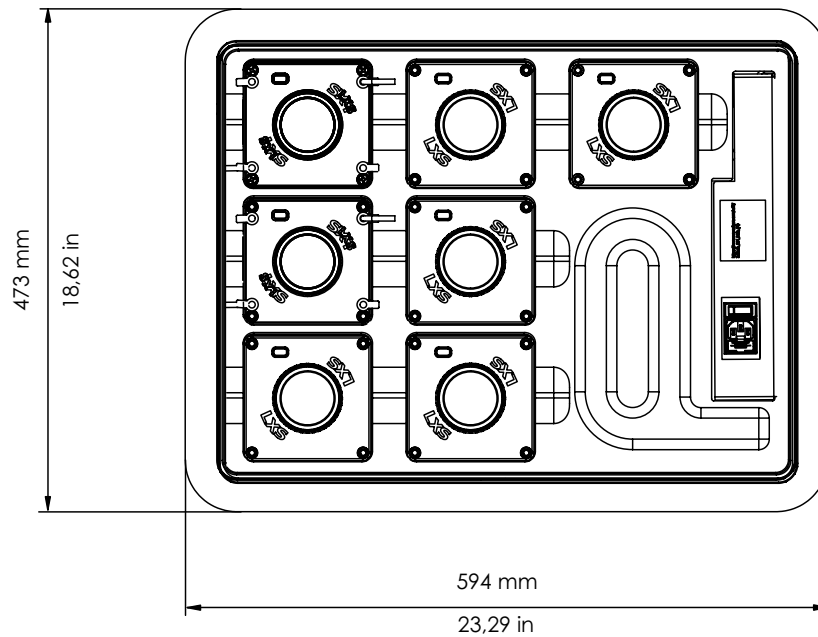

9 LIGHTS VERSION

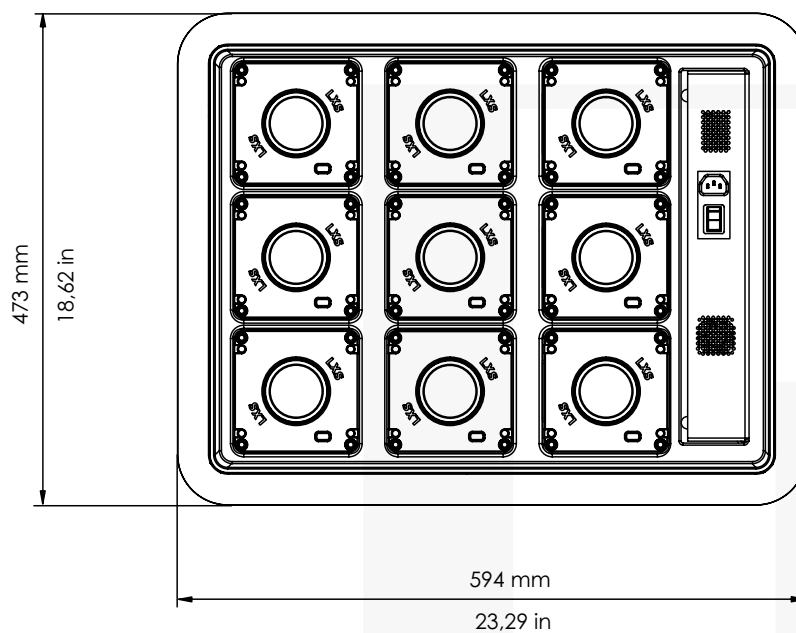

HELIPORT LIGHTS

LXS PORTABLE LIGHTING SYSTEM TECHNICAL DRAWING

SINGLE LIGHTING ELEMENT

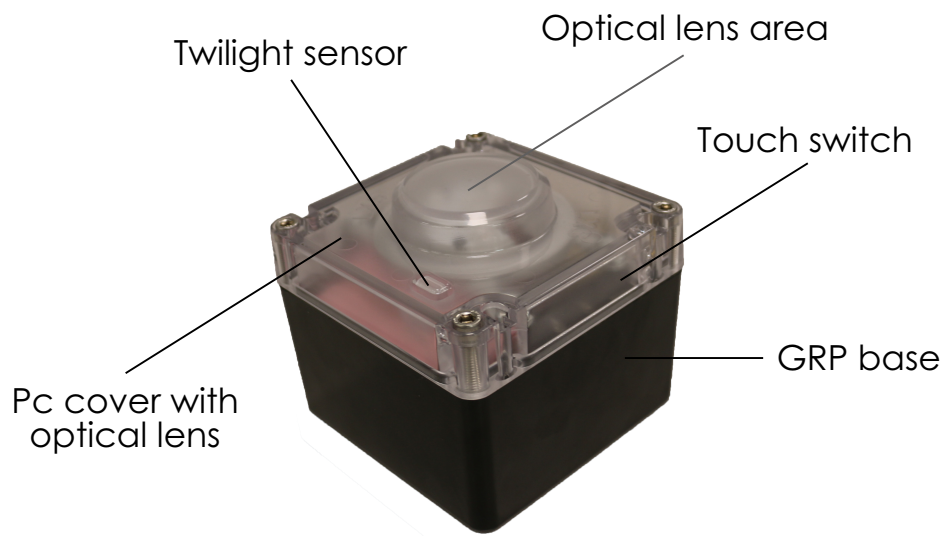

TROLLEY



RADIO RECEIVER/DECODER L854-LXS

Pilots use this device in air-to-ground communication.

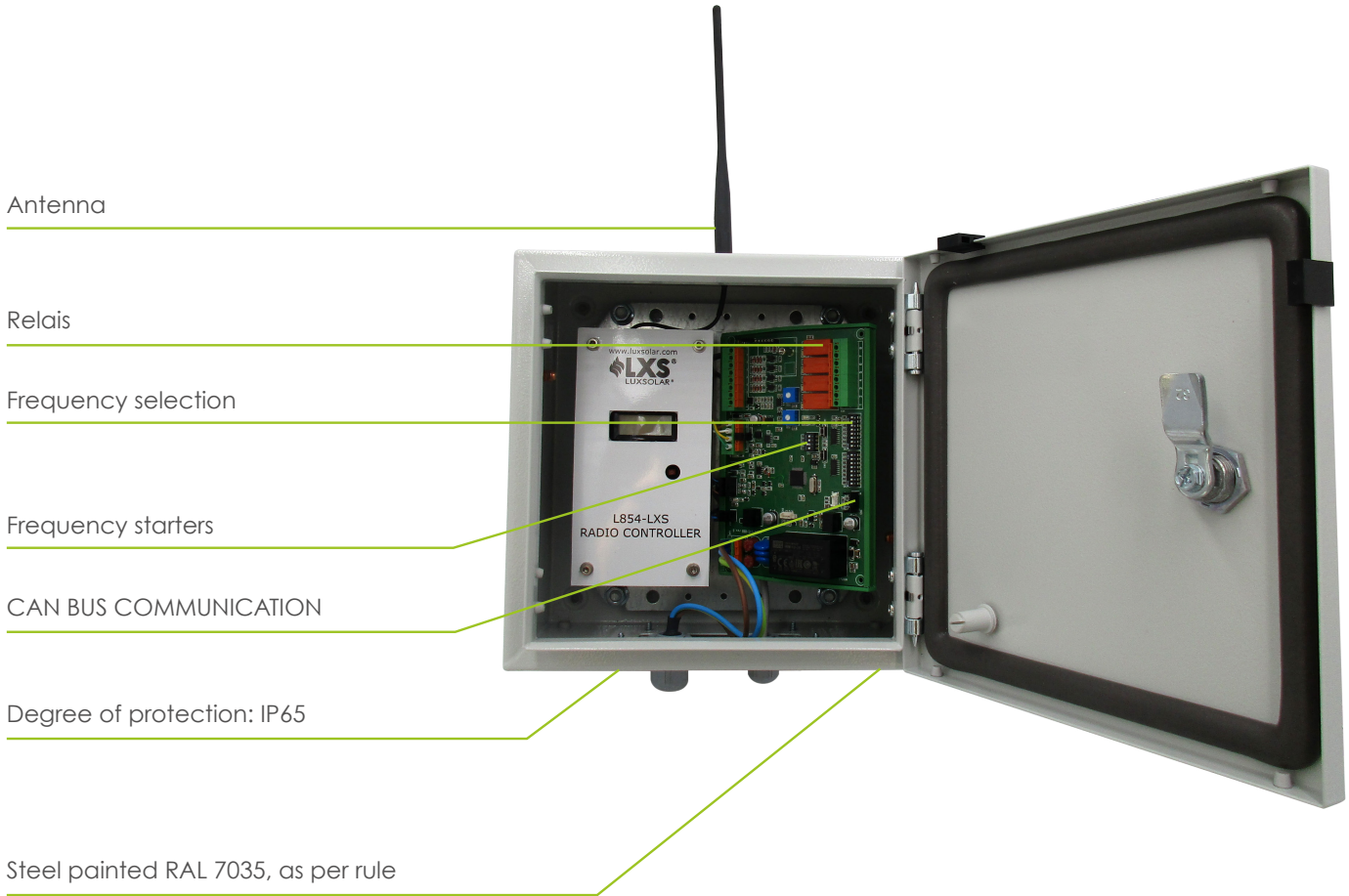

L854-LXS device lets the pilots turn on and control the heliport lighting system.

This system is essential for landing where there's no ground crew and it makes the control of the beacons (**as TLOF, WINDSOCKS, ASPSL lighting, etc.**) easier and faster.

Luxsolar has developed the Radio Receiver/Decoder L854 that, with a series of clicks, lets the pilot turn-on and set the vertiport beacons intensity.

The System is designed for automatic shutdown after 15 minutes. It allows to avoid waste and decrease the light pollution. It's possible to set the off time.

CERTIFICATIONS



COMPLIANCE



FEATURES



RADIO RECEIVER/DECODER TECHNICAL SPECIFICATIONS

OPERATION

The pilot turns the Radio System on with the on-board communication button. According to the number of clicks, the lighting system turns at different intensity on:

- **3 clicks:** low intensity
- **5 clicks:** medium intensity
- **7 clicks:** high intensity

MECHANICAL FEATURES

- FAA L854 Type I: air-to-ground
- Pilot's Control Lights (PCL) Type J: clicks turned from the PTT button on
- System enabling in 5 seconds
- Auto power off after 15 minutes of downtime
- Operating frequency: 118-136MHz
- Operating temperature: -40°C / +55°C
- Power supply: 100/240Vac 50-60Hz
- Power supply: version in continuous current is available
- CAN BUS communication

INCLUDED IN THE SYSTEM

- AM Receiver
 - Decoder Type A
 - Bandwidth: 8.33KHz or 25KHz

PART NUMBER

L854-LXS

TECHNICAL DRAWINGS

FRONT VIEW

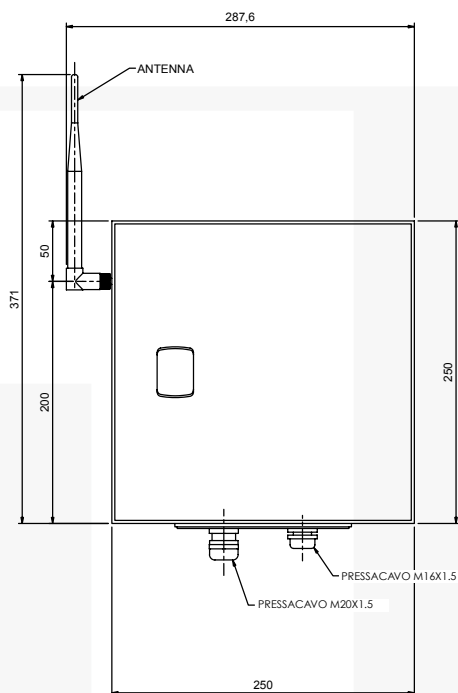

SIDE VIEW

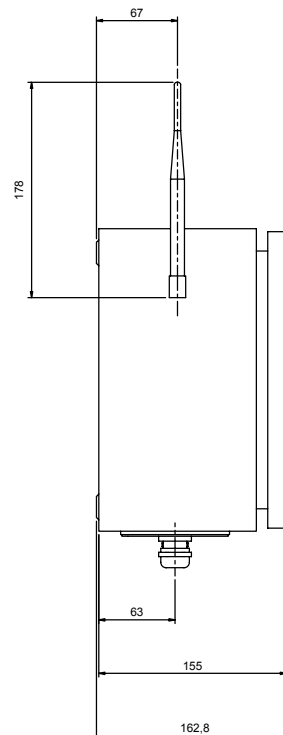





HELIDECK LIGHTS

TYPICAL INSTALLATION HELIDECK (Oil&Gas offshore)

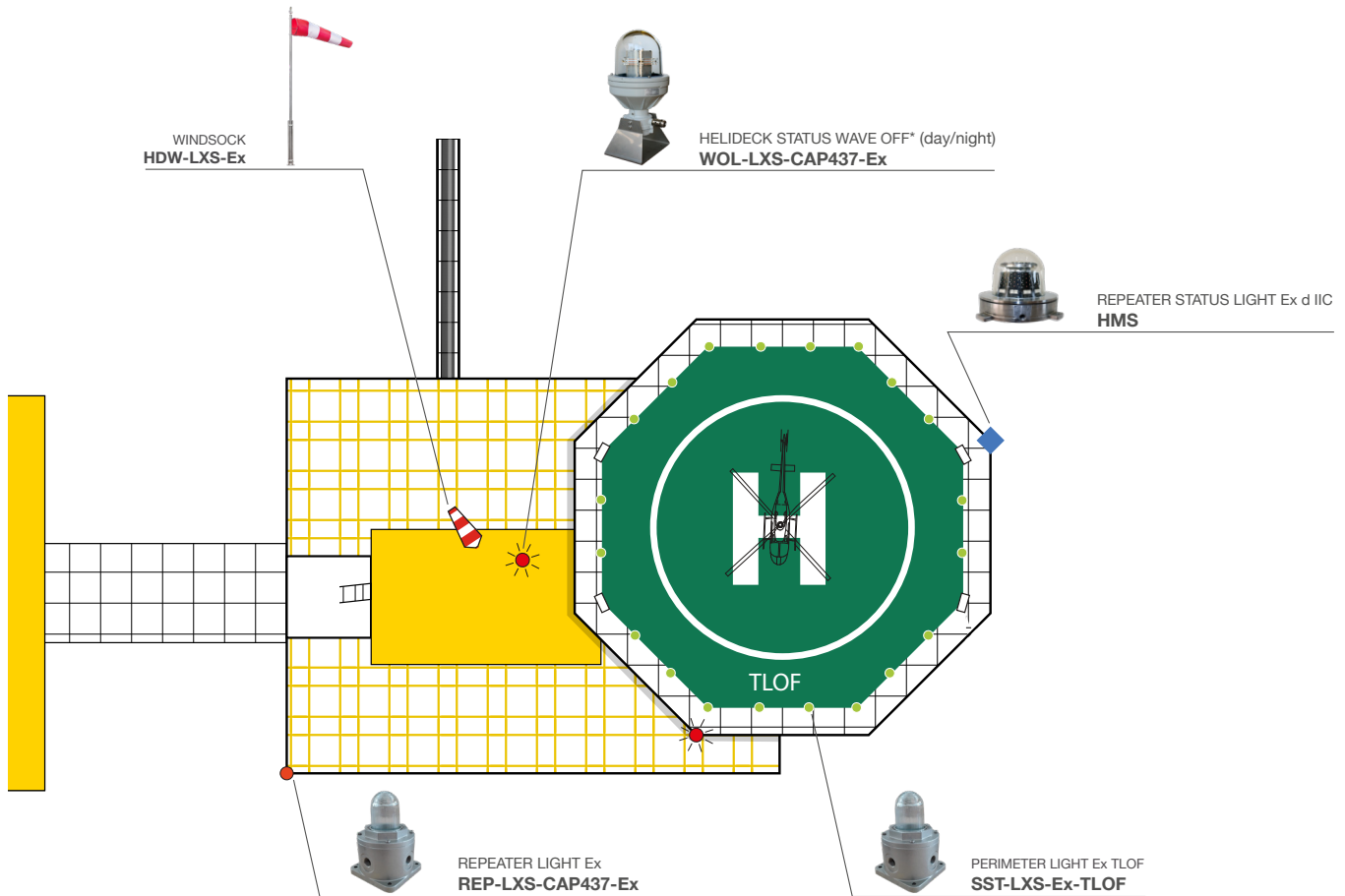

* REPEATER LIGHT and HELIDECK STATUS WAVE OFF LIGHT are compliant with CAP437

LEGEND

◆ REPEATER STATUS LIGHT Ex d IIC - HMS

● PERIMETER LIGHT Ex TLOF - SST-LXS-Ex-TLOF

☀ HELIDECK STATUS WAVE OFF - WOL-LXS-CAP437-Ex

● REPEATER LIGHT Ex - REP-LXS-CAP437-Ex

🚩 WINDSOCK Ex - HDW-LXS-Ex

Helideck: a heliport located on a fixed or floating offshore facility such as an exploration and/or production unit used for the exploitation of Oil or Gas.

(ICAO Aerodromes Annex 14 - Volume II Heliports - International Standards and Recommended Practices - Chapter 1.1-Definitions)

These lights have been designed for hazardous areas with Ex d IIC and Ex tb protection and are **ATEX**, **IECEx** certified.

HELIDECK LIGHTS

HELIDECK MONITORING SYSTEM REPEATER STATUS LIGHTS

Flame-Proof Ex db IIC, Ex tb IIIC
ZONE 1/21/2/22

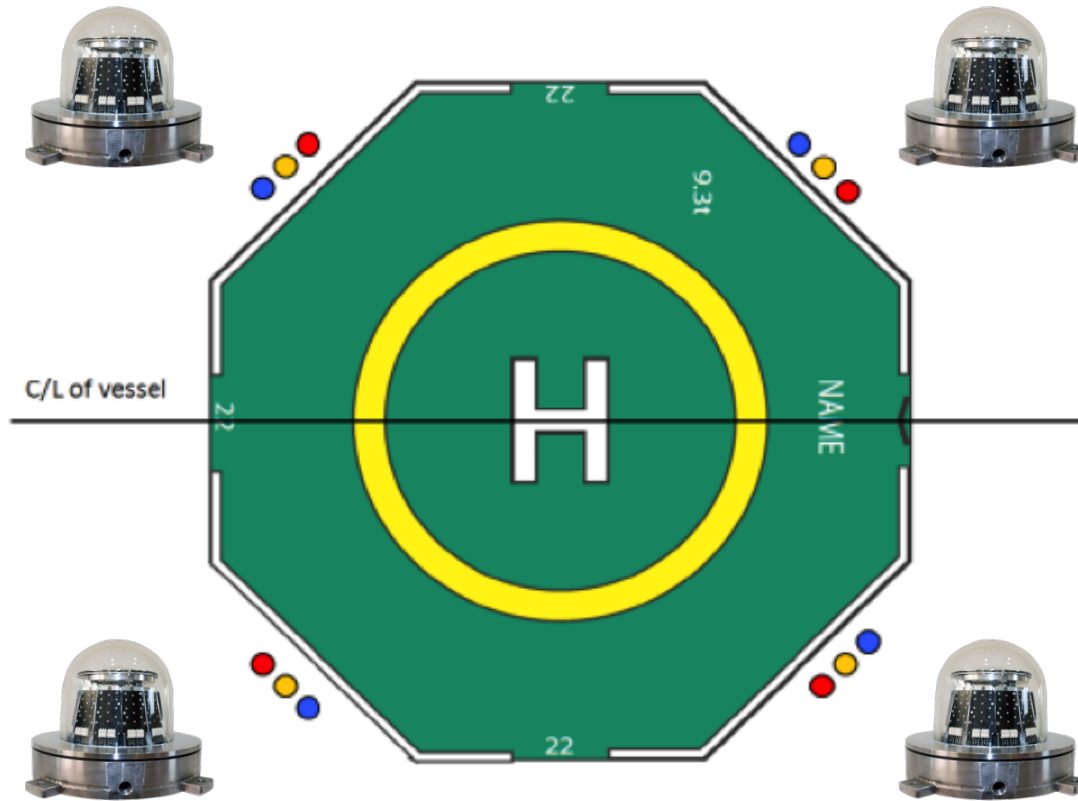

According to **CAP437 "Standards for Offshore Helicopter Landing Areas"**, from 1st April 2021 all moving helidecks must be provided with a **Helideck Monitoring System compliant with Rev.9 or later of the standard published on the Helideck Certification Agency's website.**

The standard requires that unstable/moving landing areas - such helidecks mounted on floating units - must be equipped with a Helideck Monitoring System (HMS) that analyses helideck motion to determine landing conditions. **The HMS-LXS-Ex converts this information into light signals that alert pilots to the helideck's motion status before landing, as well as any changes in weather conditions post-landing.**

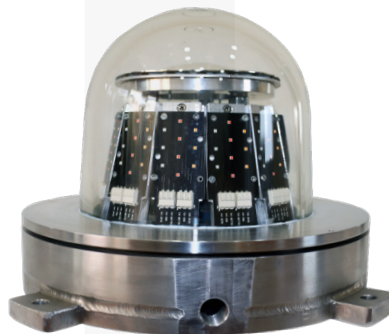

HELIDECK LIGHTS

HMS REPEATER STATUS LIGHT Ex db IIC, Ex tb IIC

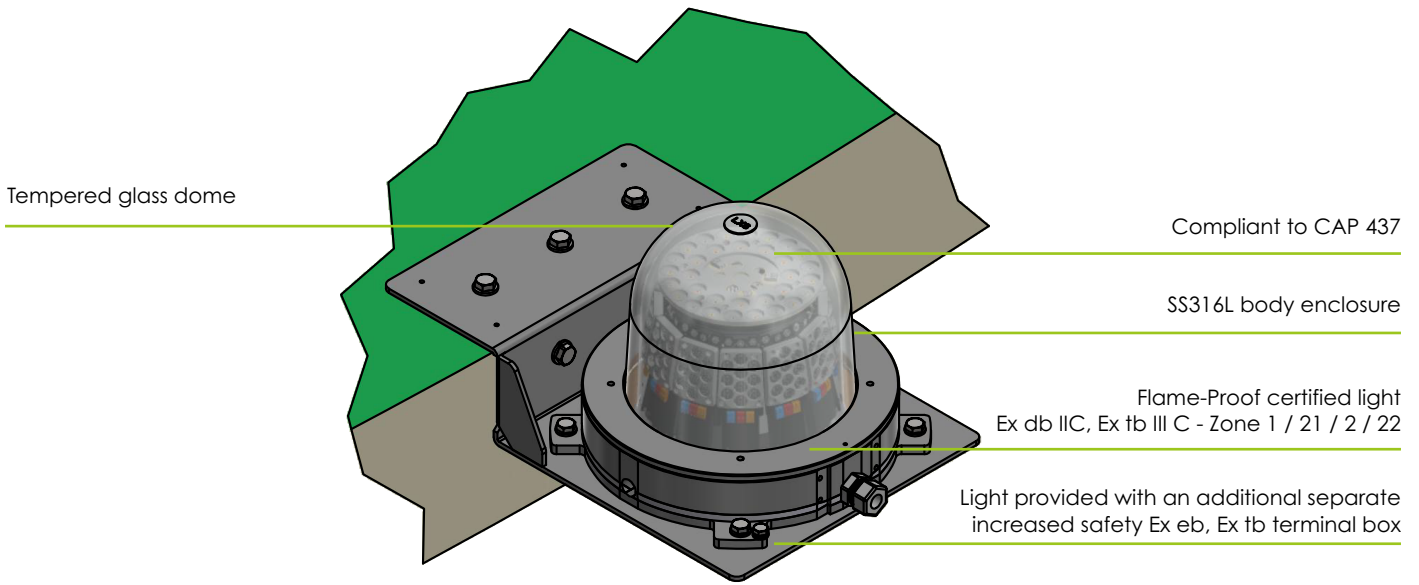

<150mm light elevation from helideck surface **IP66**

The LUXSOLAR HMS-LXS-Ex lighting fixtures are in compliance with **CAP437** and **ATEX/IECEx** certified for **Zone 1/21/2/22** according to **EN / IEC 60079-0, EN / IEC 60079-1, EN / IEC 60079-31** standards.

The body is manufactured in SS316L and the cover in borosilicate material to guarantee the maximum resistance to salt-atmosphere and harsh environments over the years. The light emission, thanks to customized lenses and ultra-bright LEDs, is certified by CAAi as in compliance with the applicable rules.

A dedicated control panel, that can be provided for safe (unclassified) or hazardous (ATEX / IECEx certified) areas, completes the system. It contains electronic boards specifically designed to receive inputs from the HMS software and to convert this information into light signals.

CERTIFICATION



FEATURES



TYPICAL APPLICATION



HELIDECK LIGHTS

HMS REPEATER STATUS LIGHT Ex db IIC, Ex tb IIC TECHNICAL SPECIFICATION

OPTICAL FEATURES

- Based on LED technology
- AMBER/RED/BLUE light in one light fixture
- FLASHING/STEADY burning mode as per CAP437 (see page 4)
- Horizontal beam radiation: 360°
- Vertical beam spread: as per CAAi rule
- ATEX execution:
II 2GD Ex db IIC T... Gb
Ex tb IIIC T...°C Db
- IECEx execution:
Ex db IIC T... Gb
Ex tb IIIC T...°C Db

LIGHT MECHANICAL FEATURES

- SS316L body material, natural finish
- SS316L fixing bracket, natural finish
- Borosilicate glass cover protection
- Degree of protection: IP66
- Ambient temperature: -50°C to +60°C
- Lamp unit weight: 19Kg approx

PANEL MECHANICAL and ELECTRICAL FEATURES

Common features:

- Complete with LUXSOLAR electronic components for HMS Repeater System operation
- Complete with 3 contacts to connect to helideck's Helideck Monitoring System
- Power consumption for HMS Repeater Light LUXSOLAR system (4HMS lights + 1 Control Panel): 400W approx

Specific features for Safe Area Control Panel:

- Available in mild steel (painted RAL7035) or SS316L (natural finish) material
- Ambient temperature: -20°C to +50°C

Specific features for Hazardous Area Control Panel:

- Available in SS316L (natural finish) or aluminium (painted RAL7035) material
- Ambient temperature: -50°C to +50°C

APPLY TO

- Vessel
- Floating Production Unit
- Semi-Submersible Rig
- Floating Jack Up Rig
- Any other moving helideck

COMPLIANCE

- CAP437 - Standards for Offshore Helicopter Landing Area
- Standard Measuring Equipment for Helideck Monitoring System (HMS) and Weather Data

CERTIFICATION

- Statement of Compliance issued by CAAi
- ATEX certificate: EPT 23 ATEX 5254X
- IECEx certificate: IECEx EUT 23.0012X
- CE marking

ORDER CODE

HLW-LXS-Ex

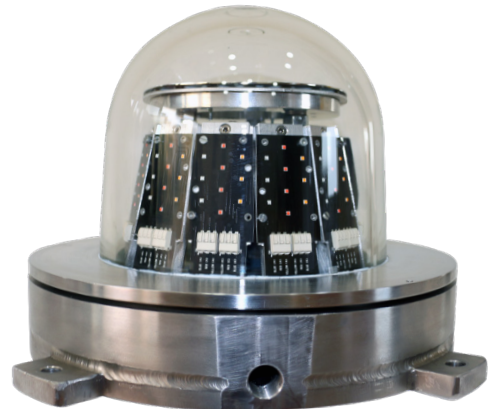

ORDER CODE

HMS-LXS-Ex-

Number of lights per system = N

IP = Panel suitable for safe area
Ex = Panel suitable for hazardous area

Note: ambient temperature and temperature classes are assigned as per Ex-certificate parameters.

HELIDECK LIGHTS

HMS REPEATER STATUS LIGHT Ex db IIC, Ex tb IIC LIGHT DISTRIBUTION STEADY

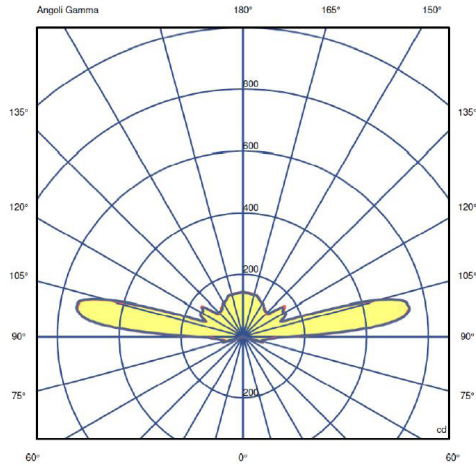

Amber Light DAY

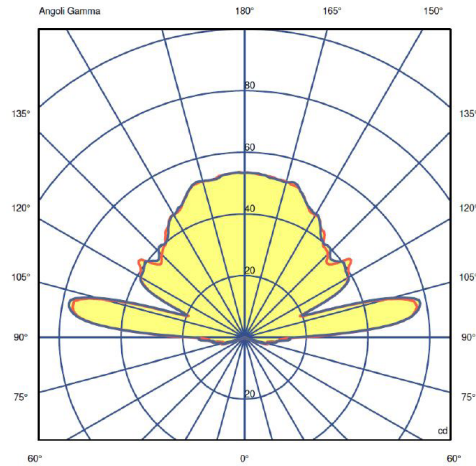

Amber Light NIGHT

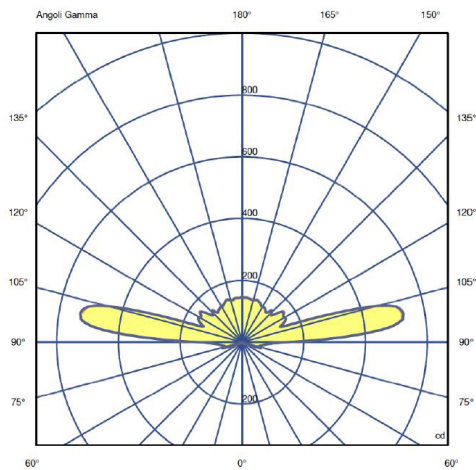

Red Light DAY

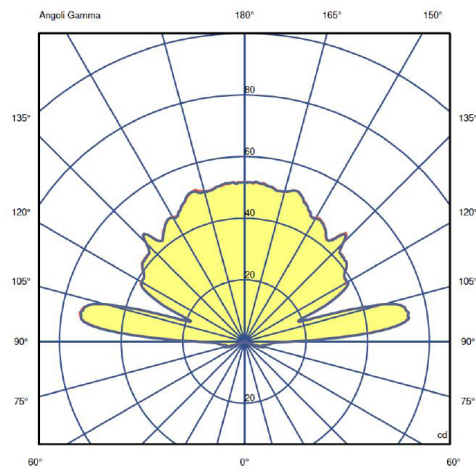

Red Light NIGHT

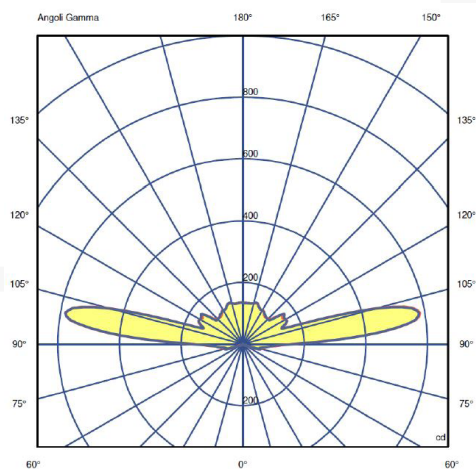

Blue Light DAY

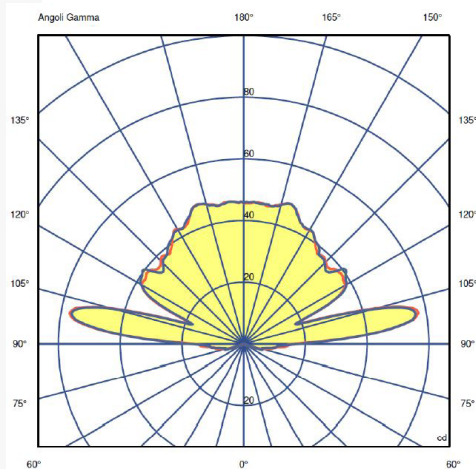

Blue Light NIGHT

HELIDECK LIGHTS

HMS REPEATER STATUS LIGHT Ex db IIC, Ex tb IIC LIGHT DISTRIBUTION FLASHING

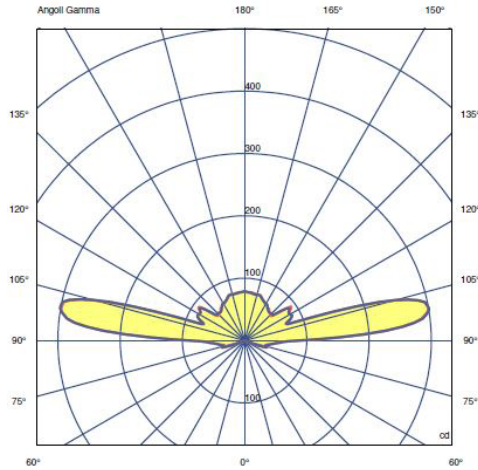

Amber Light DAY

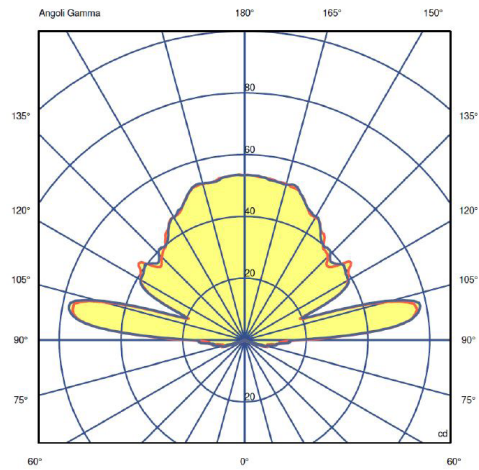

Amber Light NIGHT

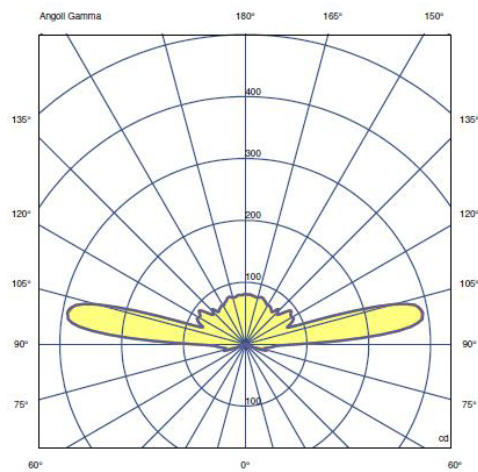

Red Light DAY

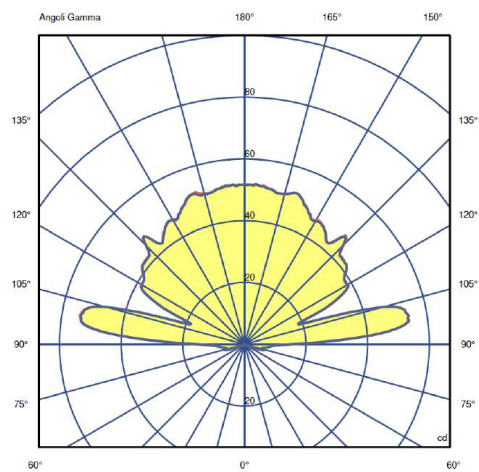

Red Light NIGHT

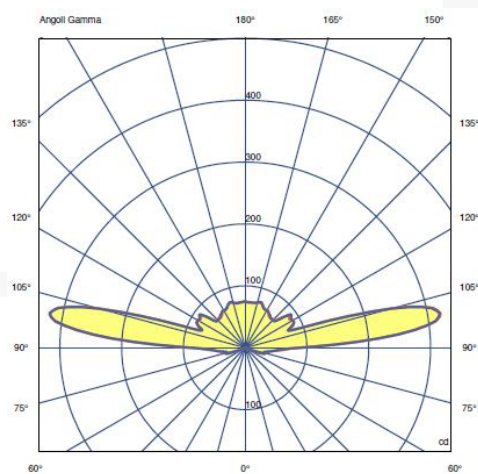

Blue Light DAY

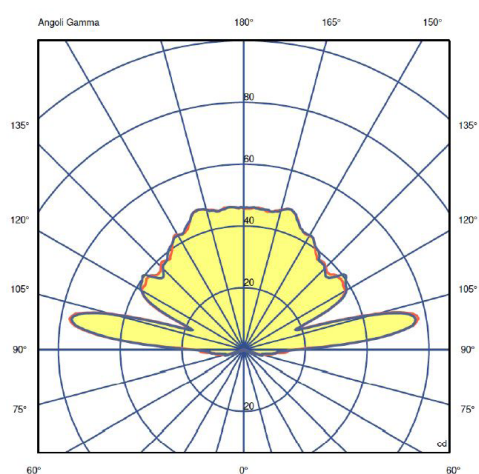

Blue Light NIGHT

HELIDECK LIGHTS

HMS REPEATER STATUS LIGHT Ex db IIC, Ex tb IIC TECHNICAL DRAWINGS

BEACON FRONT VIEW

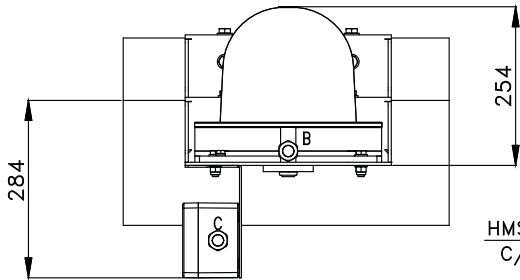

HMS_ INCOMING POWER SUPPLY CABLE
C/W CABLE GLAND ISO M25X1.5

BEACON SIDE VIEW

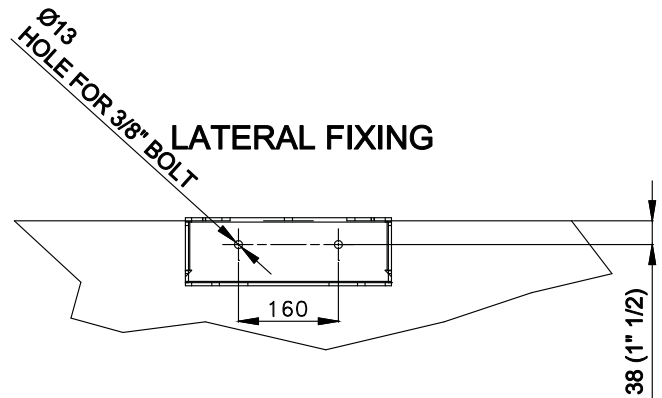
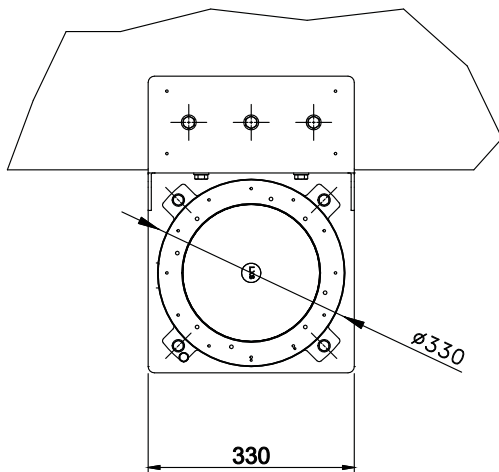
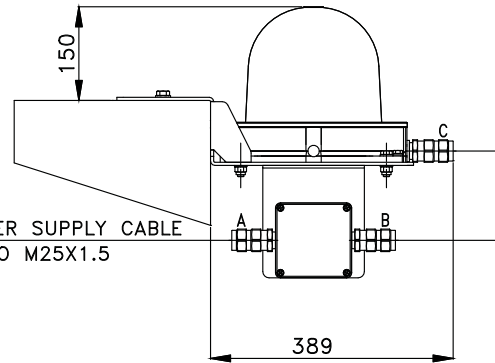

LATERAL FIXING

TOP FIXING

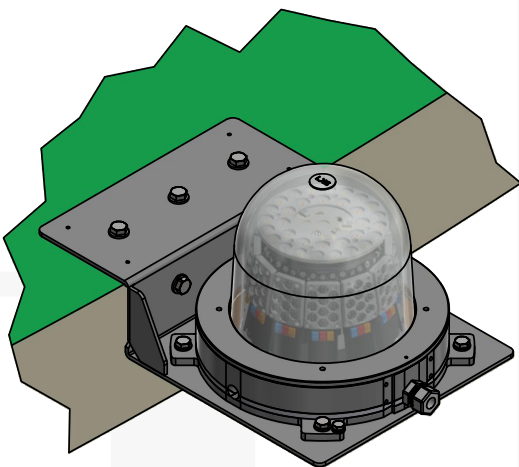
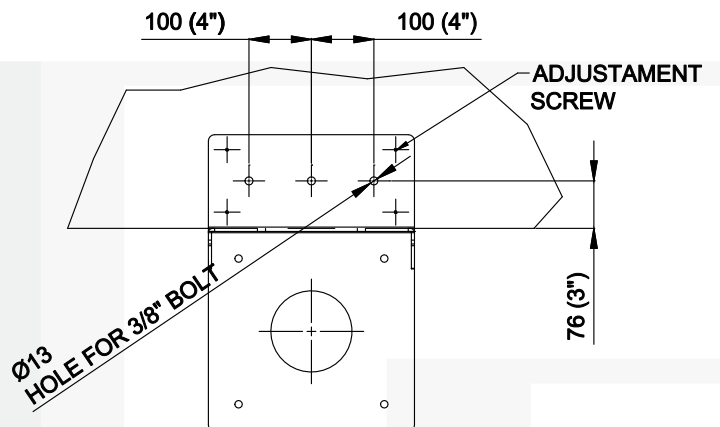

HELIDECK LIGHTS

HMS REPEATER STATUS LIGHT Ex db IIC, Ex tb IIC TECHNICAL DRAWINGS

TYPICAL CONFIGURATION HAZARDOUS AREA

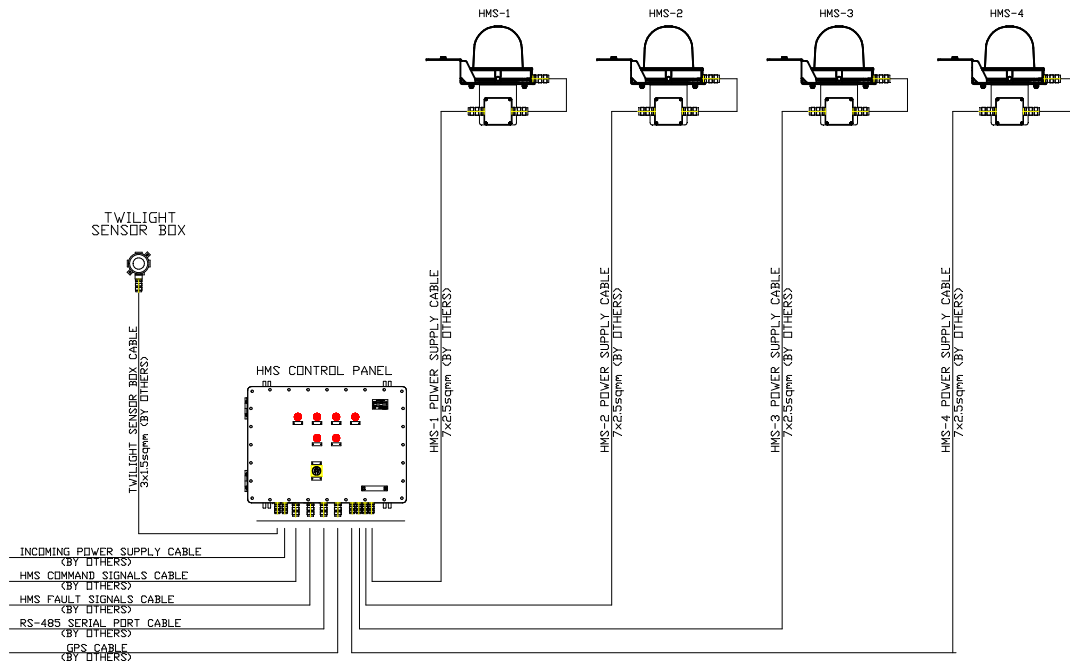

TYPICAL CONFIGURATION SAFE AREA PANEL

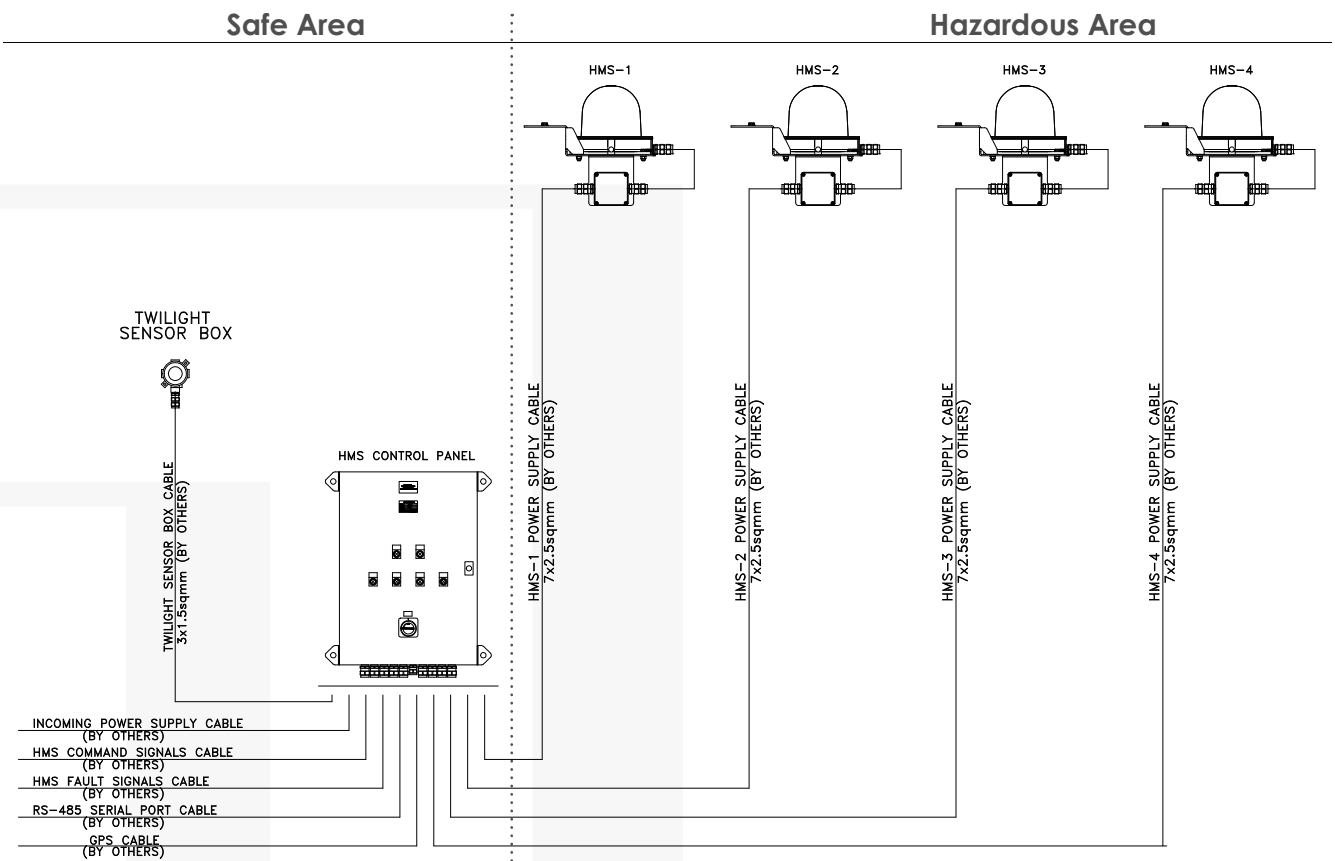

HELIDECK LIGHTS

HELIDECK STATUS WAVE OFF LIGHT WOL-LXS-CAP437-Ex



- Colour aviation: **RED flashing 120fpm**
- **Min. 700cd between 2° - 10° and at least 176cd at all other angles of elevation**
- **Intensity dimmers to 60cd while helicopter is landed on deck and flash rate dimmers to 60fpm**
- Long life time **>10 years** life expectancy
- **Low** consumption
- **Stabilised light** output
- **Low wind** load factor
- **Easy** to install
- **Light intensity emission adjustable from remote**
- **Degree of protection:** IP66
- **ATEX execution:**
II 2GD Ex db eb IIC T4 ... Gb;
Ex tb IIIC T135°C Db
- **IECEx execution:**
Ex db eb IIC T4 Gb
Ex tb IIIC T135°C Db

PATENTED

NOTE: Electronic components to be installed in a dedicate enclosure

CERTIFICATION



COMPLIANCE



FEATURES



TYPICAL APPLICATION



HELIDECK LIGHTS

HELIDECK STATUS WAVE OFF LIGHT TECHNICAL SPECIFICATION AND DRAWING

OPTICAL FEATURES

- Based on LED technology
- Horizontal beam radiation 360°
- PMMA lens
- Vertical beam spread:

| Elevation (E) | Luminous Intensity |
|-----------------------------|--------------------|
| $2^\circ < E \leq 10^\circ$ | min. 700cd |
| $>10^\circ$ | 176cd |

-180° Azimuth +180°

MECHANICAL FEATURES

- Painted aluminium body, painted RAL 7035
- Borosilicate glass cover protection
- Terminal box for 2,5mm² wires
- Degree of protection: IP66
- Operating temperature: -52°C to +60°C
- Unit weight: 16kg

ELECTRICAL FEATURES

- Power supply 12/24Vdc or 115/230Vac from Luxsolar control panel
- Power consumption 56W
- LED fedded at constant current

APPLY TO

- The aeronautical meaning of a flashing red light is either "do not land, aerodrome not available for landing" or "move clear of landing area"

CERTIFICATE

- ATEX certificate
- IECEx certificate
- CE marking

COMPLIANCE

- CAP437 "Standard for offshore Helicopter denoting Areas", par. 4.25
- CAA Paper 2008/01 "Specification for an offshore helideck status light system"

ORDER CODE

WOL-LXS-CAP437-EX-8

FRONT VIEW

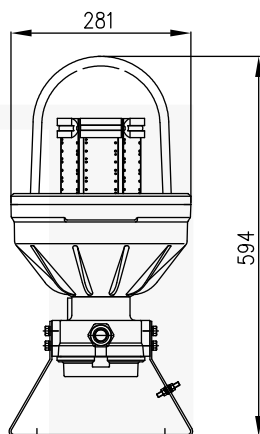

SIDE VIEW

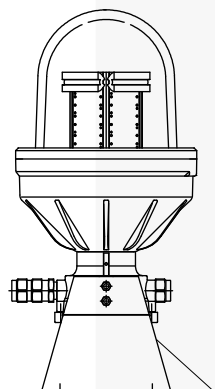

FIXING DETAILS

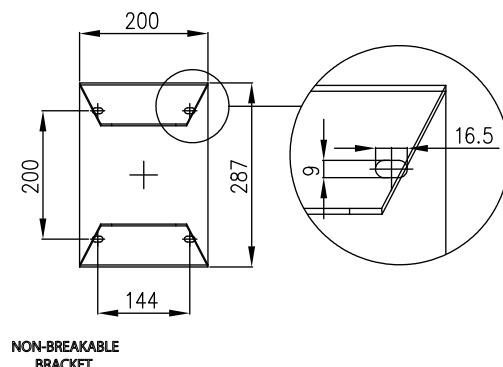

HELIDECK LIGHTS

PERIMETER LIGHT Ex - TLOF SST-LXS-Ex-TLOF



- **Steady burning GREEN light**
- Long life time **>10 years** life expectancy
- **Low** consumption
- **Stabilised** light output
- **Easy** to install
- **No RF-radiations**
- **ATEX execution:**
 - II 2GD Ex db IIC T...Gb;
 - Ex tb IIIC T...Db
- **IECEx execution:**
 - Ex db IIC T... Gb;
 - Ex tb IIIC T...Db

NOTE: Electronic components to be installed in a dedicate enclosure

CERTIFICATION



COMPLIANCE



FEATURES



TYPICAL APPLICATION



HELIDECK LIGHTS

PERIMETER LIGHT Ex - TLOF TECHNICAL SPECIFICATION AND DRAWING

OPTICAL FEATURES

- Horizontal beam radiation 360°

| Elevation (E) | Luminous Intensity |
|-------------------------------|--------------------|
| $20^\circ < E \leq 90^\circ$ | 3 cd |
| $13^\circ < E \leq 20^\circ$ | 8 cd |
| $10^\circ < E \leq 13^\circ$ | 15 cd |
| $5^\circ < E \leq 10^\circ$ | 30 cd |
| $2^\circ \leq E \leq 5^\circ$ | 15 cd |

-180° Azimuth +180°

MECHANICAL FEATURES

- Natural finish SS316L body
- Borosilicate Glass Dome
- Degree of protection: IP66
- Operating temperature: -40°C to +70°C

ELECTRICAL FEATURES

- AC power supply 230VAC
- LED feeded at constant current

OPTIONS

- Power supply 24VDC

CERTIFICATIONS

- ATEX certificate
- IECEx certificate
- CE marking

COMPLIANCE

- CAP437 "Standard for offshore Helicopter donating Areas", Chapter 4
- ICAO, Annex 14, Vol. II - Heliports - par. 5.3.7
- ICAO, Heliport Manual, Ed. III - par. 5.2.3.8

ORDER CODE

SST-LXS-Ex-TLOF

TOP VIEW

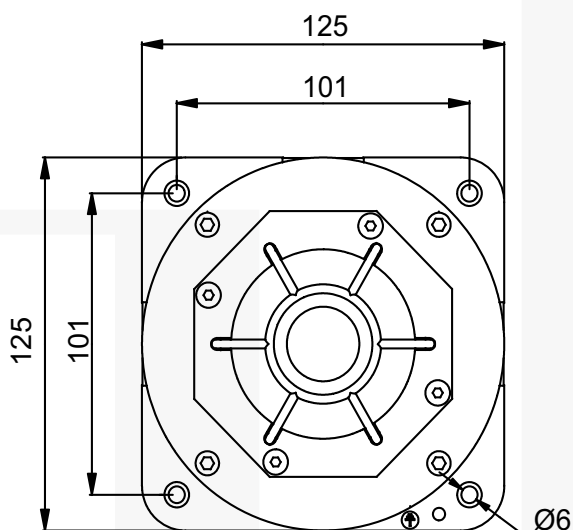

LATERAL VIEW

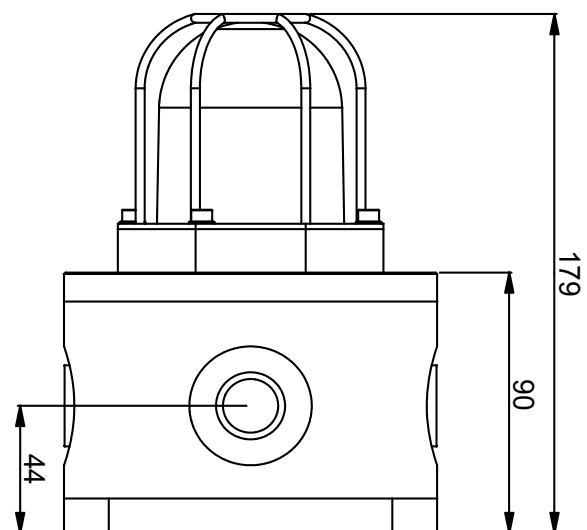

HELIDECK LIGHTS

REPEATER LIGHT Ex SST-LXS-EX-REP



- **Steady burning RED light**
- Long life time **>10 years** life expectancy
- **Low** consumption
- **Stabilised** light output
- **Easy** to install
- **No RF-radiations**
- **ATEX execution:**
II 2GD Ex db IIC T...Gb;
Ex tb IIIC T...Db
- **IECEX execution:**
Ex db IIC T... Gb;
Ex tb IIIC T...Db



CERTIFICATION



COMPLIANCE



FEATURES



TYPICAL APPLICATION



HELIDECK LIGHTS

REPEATER LIGHT Ex TECHNICAL SPECIFICATION AND DRAWING

OPTICAL FEATURES

- Horizontal beam radiation 360°

| Elevation | Azimuth | Intensity (min) |
|-----------|----------------|----------------------|
| 0° to 90° | -180° to +180° | min 16cd max 60cd |

MECHANICAL FEATURES

- Natural finish SS316L body
- Borosilicate Glass Dome
- Degree of protection: IP66
- Operating temperature: -40°C to +70°C

ELECTRICAL FEATURES*

- AC power supply 230VAC
- LED feeded at constant current

OPTIONS

- Power supply 24VDC

CERTIFICATIONS

- ATEX certificate
- IECEx certificate
- CE marking

COMPLIANCE

- CAP437 "Standard for offshore Helicopter denoting Areas"
- CAA Paper 2008/01 "Specification for an offshore helideck status light system"

ORDER CODE

SST-LXS-EX-REP

TOP VIEW

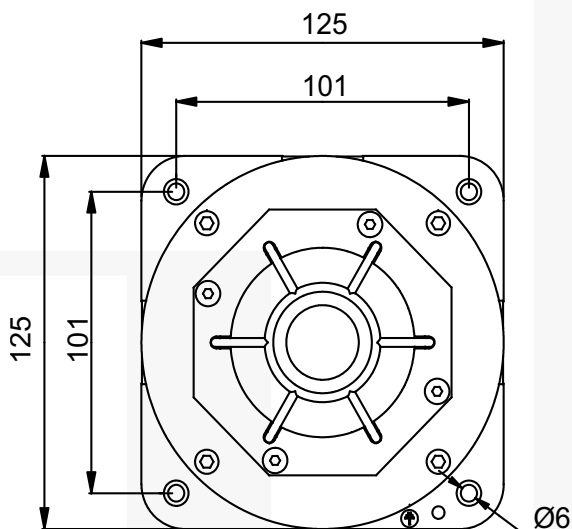

LATERAL VIEW

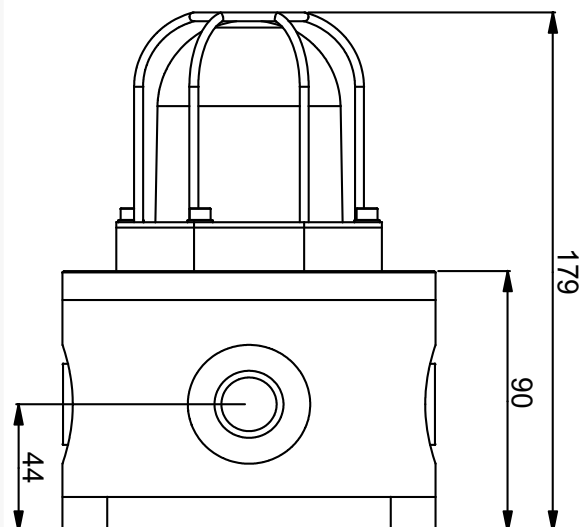

HELIDECK LIGHTS

HELIDECK WINDSOCK COLLAPSIBLE VERSION

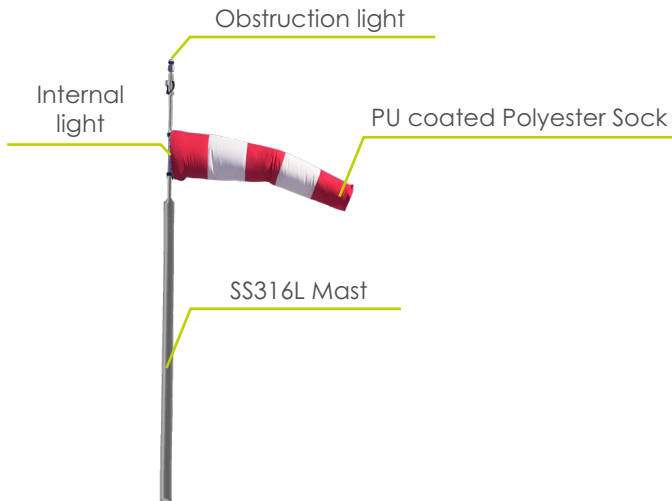

- **Sock colour: ORANGE/WHITE/RED&WHITE stripes**
- **Designed to be visible from up to 200m**
- **Collapsible mechanism***
- **Compliance: ICAO**
- **Ex marking for lights used:**
 - II 2 GD Ex de IIC T6 Gb
 - Ex tb IIIC T67°C Db, IP66

* Collapsible mechanism: when a helicopter hits the Windsock mast, the pole falls to the ground without breaking

NOTE: Lights are covered by ATEX or IECEx certificate

CERTIFICATION



COMPLIANCE



FEATURES



TYPICAL APPLICATION



HELIDECK LIGHTS

HELIDECK WINDSOCK

TECHNICAL SPECIFICATION AND DRAWING

KEY FEATURES

- Sock colour: ORANGE/WHITE/RED&WHITE stripes
- Designed to be visible from up to 200m

MECHANICAL FEATURES

- Sock material: Polyester PU coated
- Sock dimensions: 2,4m long x 0,60m mouth diameter x 0,30m tail diameter
- Mast material: SS316L natural finish (not painted), collapsible mechanism
- Mast height: 3m to windsock centerline

CERTIFICATIONS

- CE marking

COMPLIANCE

- ICAO Annex 14 Vol. II Heliports - Chapter 5
- ICAO Annex 14 Vol. I Visual Aids - Chapter 5

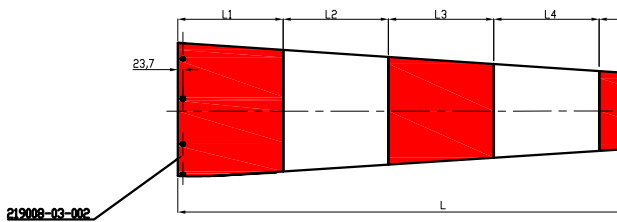

| STANDARD WINDSOCK MAST WITH INTERNAL LIGHTING | |
|---|-----------|
| Base Plate Measurements | 280x280mm |
| Height of Windsock above Ground | >3m |
| Windsock Throat Opening | 600mm |
| Windsock Length | 2400mm |

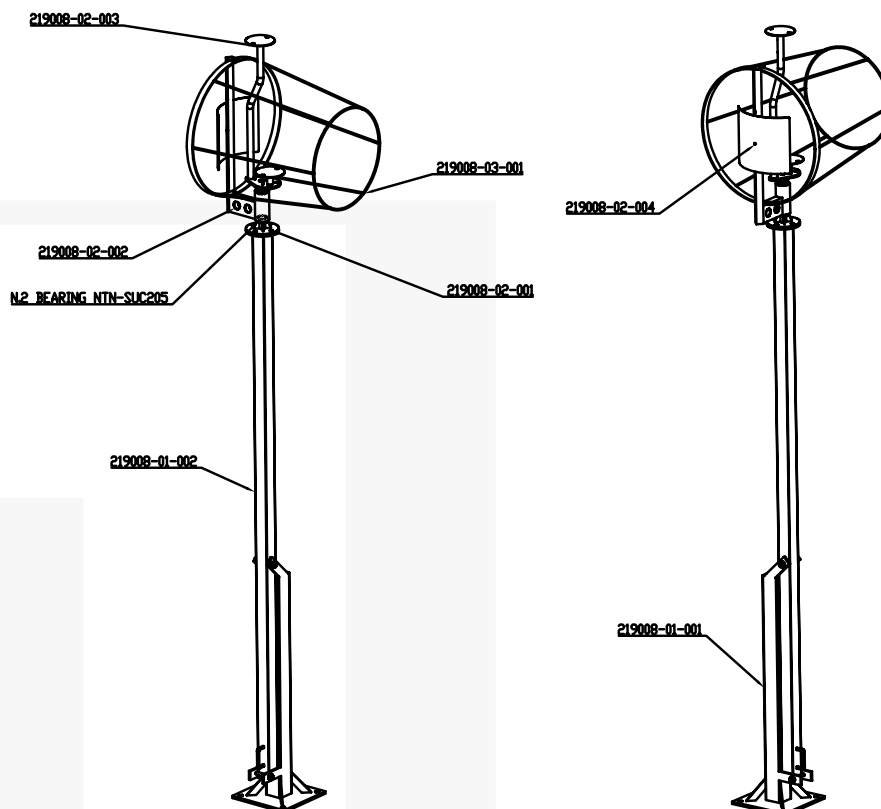

NOTES

NOTES

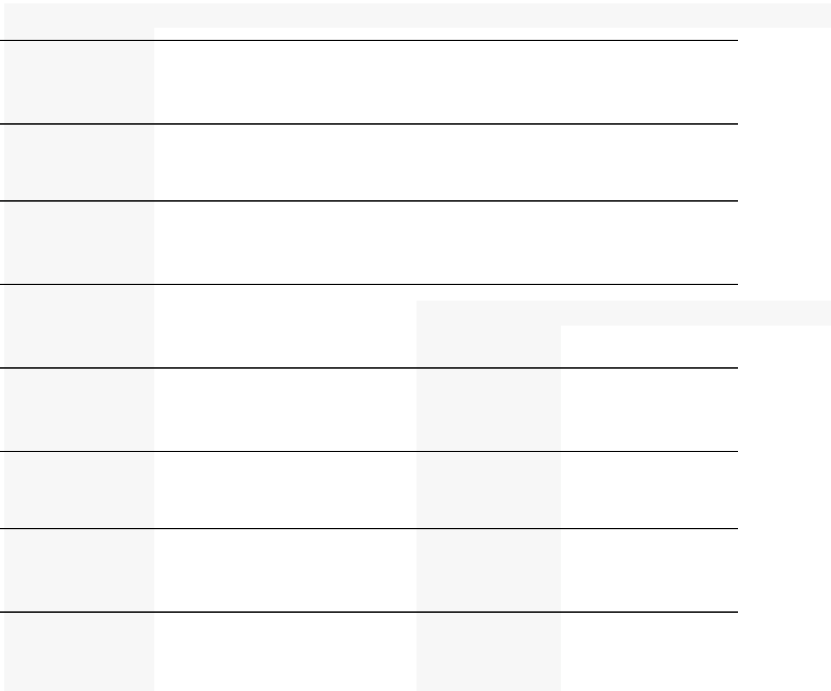

CONTACTS

CE2K S.r.l. - Luxsolar®

Phone: +39 0341-260926

E-mail: info@ce2k.com - lxs@luxsolar.com

Web sites: www.ce2k.com - www.luxsolar.com

- **LinkedIn:** Luxsolar Italia



- **YouTube:** Luxsolar





Luxsolar® is a department of CE2K S.r.l.
Via Sabatelli 38, 23868 Valmadrera (LC) - Italy



www.luxsolar.com