

LOW INTENSITY

LOW INTENSITY AWL SYSTEM CONTROL BOX



LUXSOLAR L810-LXS-CB is a unit designed to control SINGLE or TWIN Low Intensity L810-LXS beacons.

The installation of more than one signalling device on the same obstacle is defined AWL system. To simplify management of AWL system composed by Low Intensity Obstruction Lights we designed L810-LXS-CB unit to control up to nr. 08 SINGLE L810-LXS or up to no. 04 TWIN L810-LXS beacons.

For an easy beacons' control and maintenance, with the L810-LXS-CB you will be able to activate the system, manage fault contacts and test the lamps from one unique small control box. L810-LXS-CB box and related beacons are then an ideal solution for AWL configurations where reliability and reduced dimension are needed.



LOW INTENSITY

LOW INTENSITY CONTROL BOX TECHNICAL SPECIFICATIONS



OPTICAL FEATURES

- Based on LED technology
- RED light - Steady Burning
- RED light - Flashing
- LIOL-A: >10 cd
- LIOL-B: >32 cd
- LIOL-E: >32 cd (flashing light 20 - 40 fpm)
- Horizontal beam radiation: 360°

LIGHT MECHANICAL FEATURES

- Anodised aluminium body with heat-sink pins for maximum heat dissipation
- Polycarbonate UV resistant dome
- Terminal JB for connection in Glass Reinforced Polyester (GRP), black colour
- Degree of protection: IP66
- Operating temperature: -20°C to +50°C
- TWIN version: two separate LED circuits in the same fixture (normal + stand-by)

BOX MECHANICAL FEATURES

- Enclosure material: Glass Reinforced Polyester (GRP), black colour
- Anticondensation Goretex valve
- Degree of protection: IP65
- Box dimension: 120x220x90mm
- Weight: 1,5kg approx
- Operating temperature: - 20°C /+ 50°C

ORDER CODE

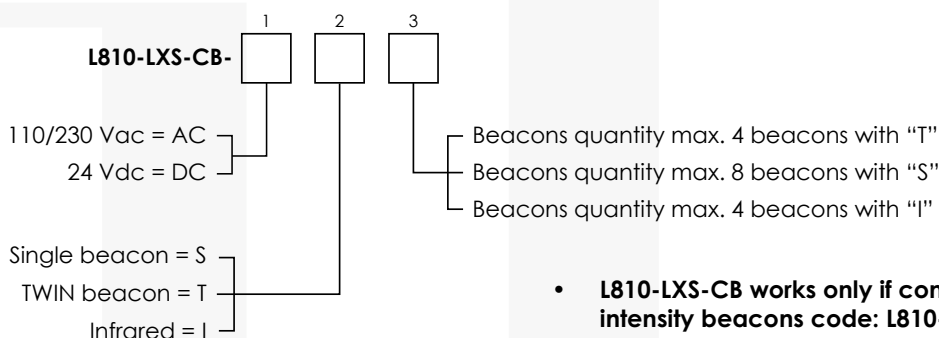

- **L810-LXS-CB works only if connected to LUXSOLAR low intensity beacons code: L810-LXS-[...]GS8R8S/GS8R8T/GS8R8I**

ELECTRICAL FEATURES

- Power supply 18/32VDC or 110/230VAC 50/60Hz
- Beacon electronic alarms available on terminals
- Overvoltage protection
- Twilight sensor
- Lamp test button
- Automatic changeover from normal to stand-by LED circuit

OPTIONS

- TWIN version: two separate LED circuits in the same fixture (normal + stand-by)
- IR Wavelength - 850nm, compatible with pilot's NVG
- A GPS module can be installed for multiple systems controlling LIOL-E beacons (low intensity flashing red light)
- LUXSOLAR® Cloud Monitoring System

APPLY TO

- Tower crane
- Transmission line
- Radio and television tower
- Wind mast measurement
- Antenna

CERTIFICATIONS

- DGAC/STAC approval nr. 2013A048
- ENAC approval nr. 0135182/ENAC/CIA
- EASA test report (EN17025 laboratory) nr. 326-QL20-R03/R04
- CE marking

COMPLIANCE

- ICAO Aerodromes -Annex 14 Volume 1, Chapter 6: Low intensity, Type A-B steady burning obstacle light, Type E flashing obstacle light
- FAA AC150/5345-43; E.B. #67 type L-810
- EASA CS-ADR-DSN, Chapter Q

LOW INTENSITY

LOW INTENSITY CONTROL BOX TECHNICAL SPECIFICATIONS

CONFIGURATION WITH N°08 SINGLE LIOL-B

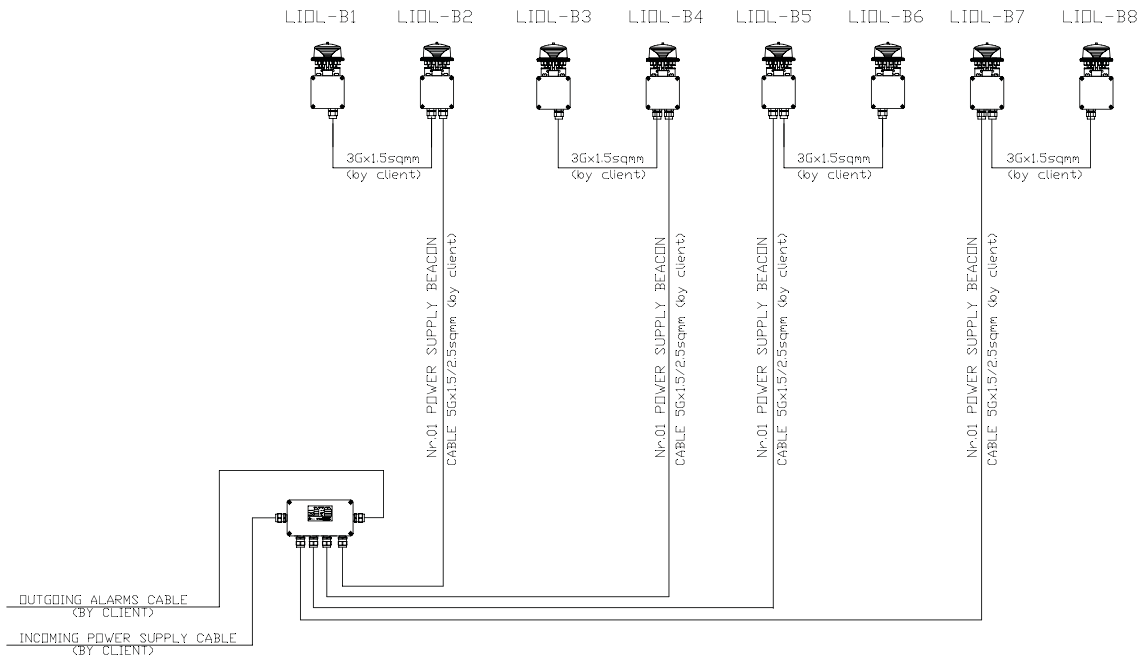

Maximum distance with 1,5sqmm cable: 300mt
Maximum distance with 2,5sqmm cable: 500mt

CONFIGURATION WITH N°04 TWIN LIOL-B

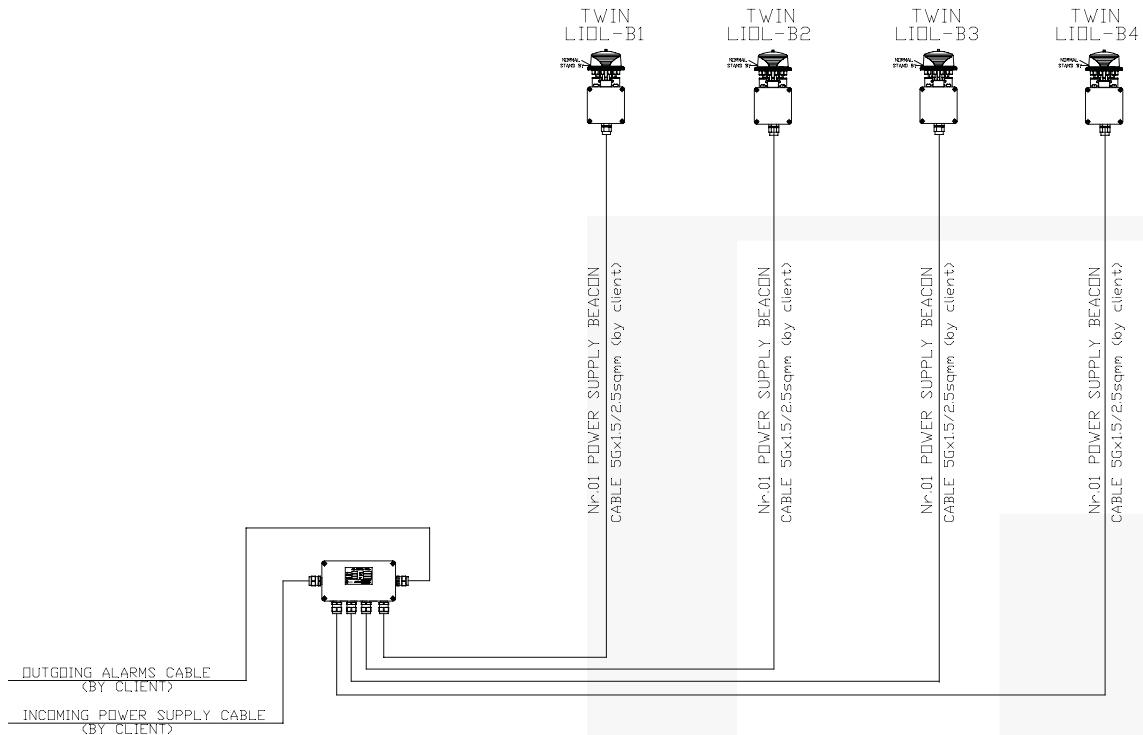

Maximum distance with 1,5sqmm cable: 300mt
Maximum distance with 2,5sqmm cable: 500mt

LOW INTENSITY

LOW INTENSITY CONTROL BOX TECHNICAL DETAILS

BOX GRP TECHNICAL DETAIL

RIGHT SIDE VIEW

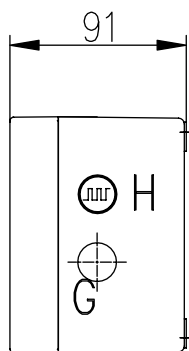

FRONT VIEW

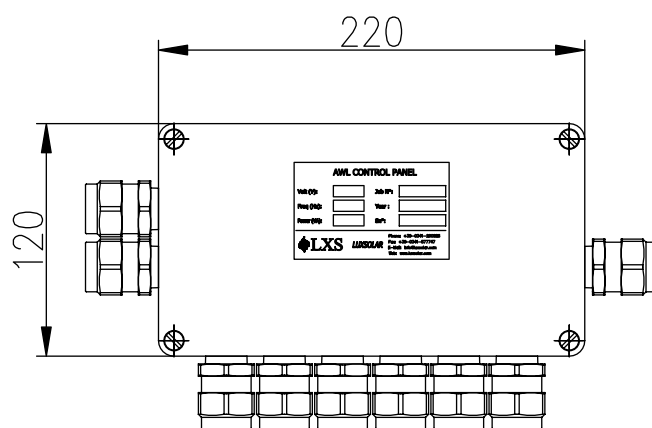

LEFT SIDE VIEW

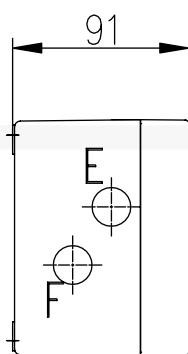

FLIXING DETAILS

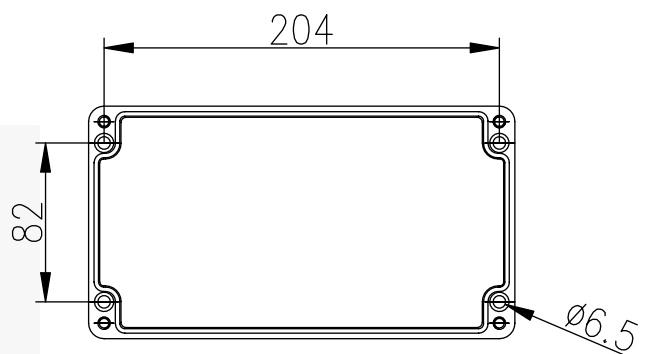

LOW INTENSITY

LOW INTENSITY CONTROL BOX TECHNICAL SPECIFICATIONS

LIOL GRP TECHNICAL DETAIL

