

LOW INTENSITY

LOW INTENSITY OBSTRUCTION LIGHT



As specified by Annex 14 of ICAO regulation, Low Intensity Obstruction Lights (LIOL) should be used to warn the presence of obstacles up to 45m height, such as chimneys, cranes, flares and other structures.

Low Intensity Obstruction Lights are the simplest devices according to ICAO standards and they have the following characteristics and uses:

- LIOL Type A (intensity $>10\text{cd}$, red steady burning) can be used alone;
- LIOL Type B (intensity $>32\text{cd}$, red steady burning), can be used either alone or in combination with medium intensity obstacle lights Type B or Type AB;
- LIOL Type E (intensity $>32\text{cd}$, red flashing), can be used either alone or in combination with medium intensity obstacle lights, Type B. Flashing rate will be set at the same rate of other flashing beacons installed on the structure.



LOW INTENSITY

LIOL-A EX/LIOL-B EX/LIOL-E EX LOW INTENSITY OBSTRUCTION LIGHT

Twilight sensor*

Stabilised light output:

- LIOL-A: >10cd
- LIOL-B: >32cd
- LIOL-E: >32cd

Based on LED technology
Red flashing light
Red steady burning light

- Standard circuits or TWIN*
- Infrared version*

Borosilicate glass dome

Cable gland M25x1,5

Painted RAL 7035 aluminium body

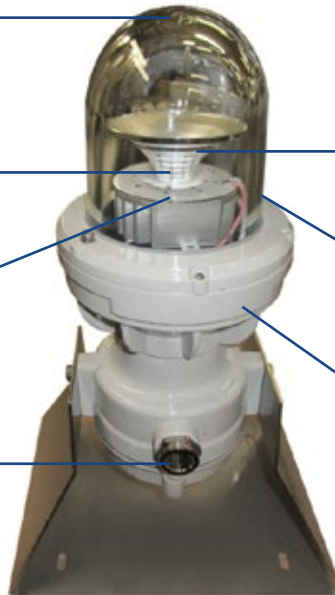

*as option

IP66



LUXSOLAR L810-LXS-Ex Low Intensity Obstruction Light is fully compliant to ICAO/EASA (Low Intensity-Type A, Bor E), FAA (Type L-810), and ATEX - IECEx - TRCU certified.

The light fixture is designed for hazardous areas Zone 1/21, 2/22 with Ex db IIC and Ex tb IIC protection, compliant to EN/IEC60079-0, EN/IEC60079-1 and EN/IEC60079-31 standards.

With a compact body, high quality and ultra-bright LEDs, optical reflector for an optimum beam spread, LUXSOLAR L810-LXS-Ex product is your best choice for an efficient, long life and reliable Aircraft Warning Obstacle Light.

CERTIFICATION



COMPLIANCE



FEATURES



TYPICAL APPLICATION



LOW INTENSITY

LIOL-A EX/LIOL-B EX/LIOL-E EX TECHNICAL SPECIFICATIONS

OPTICAL FEATURES

- Based on LED technology
- RED light - Steady Burning
- RED light - Flashing (LIOL-E)
- LIOL-A Ex: >10 cd
- LIOL-B/E Ex: >32 cd
- Cd emission: +6° and +10°
- Horizontal beam radiation: 360°
- Vertical beam spread: >10°
- Optical reflector

MECHANICAL FEATURES

- Painted RAL 7035 aluminium body
- Borosilicate glass dome
- Degree of protection: IP66
- Operating temperature: -52°C to +60°C
- Lamp unit weight: 7kg
- **ATEX marking:**
II 2GD Ex de IIC T4 Gb, Ex tb IIIC T135°C Db
- **IECEX marking:**
Ex de IIC T4 Gb, Ex tb IIIC T135°C Db
- **TRCU marking:**
I Ex de IIC T4 Gb, Ex tb IIIC T135°C Db

ELECTRICAL FEATURES

- Power supply AC or DC or from Luxsolar Control Panel
- Power consumption LIOL-A: 2W @12/24Vdc
- Power consumption LIOL-B: 2,8W @12/24Vdc
- Power consumption LIOL-E: 2W @12/24Vdc
- LED feded at costant current

ORDER CODE

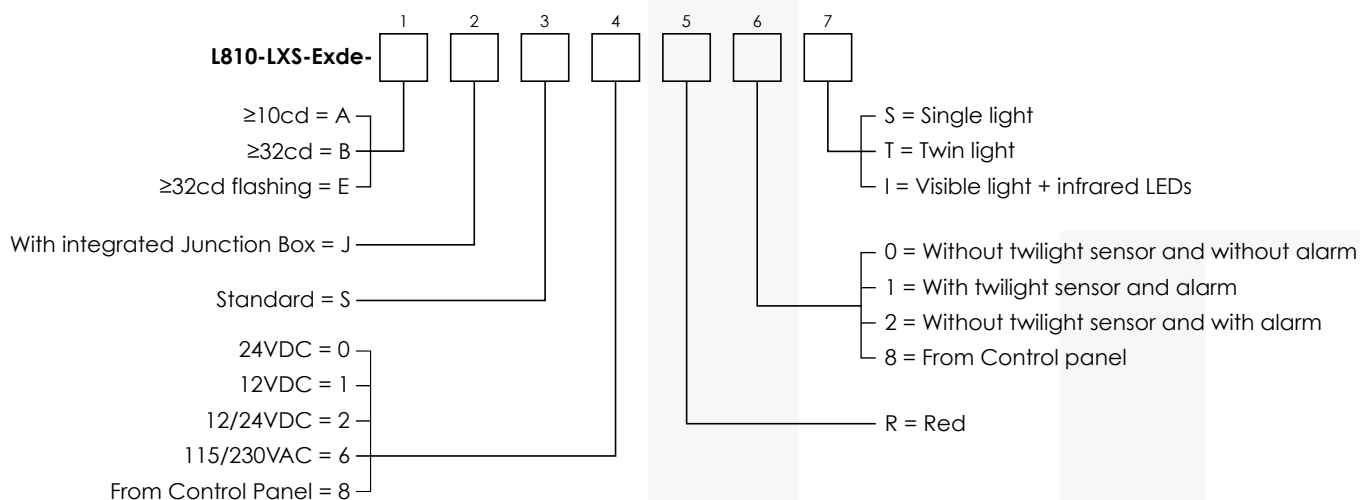

OPTIONS

- TWIN version: two separate LED circuits in the same fixture (normal + stand-by)
- Automatic changeover from normal to backup light
- Fault contact
- IR Wavelength - 850nm, compatible with pilot's NVG

APPLY TO

- Stack
- Chimney
- Tower crane
- Offshore Platform
- Chemical and petrochemical plant

CERTIFICATIONS

- ATEX certificate
- IECEX certificate
- TRCU certificate
- ICAO/EASA test report (EN 17025 marking laboratory) nr. 326-QL20-R05/R06
- CE marking

COMPLIANCE

- ICAO Aerodromes -Annex 14 Volume 1, Chapter 6: Low intensity, Type A-B steady burning obstacle light, Type E flashing obstacle light
- FAA AC150/5345-43; E.B. #67 type L-810
- EASA CS-ADR-DSN, Chapter Q

LOW INTENSITY

LIOL-A EX/LIOL-B EX/LIOL-E EX TECHNICAL SPECIFICATIONS

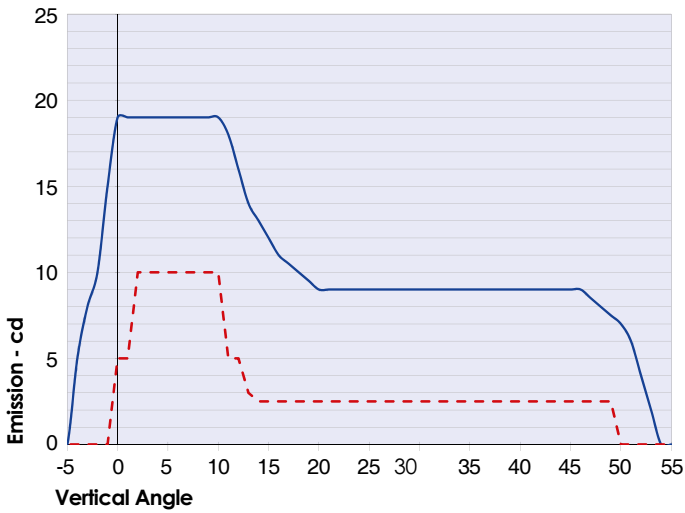

— L810-LXS-A Exde average emission level
- - - ICAO ANNEX 14 low intensity type A Minimum Required Intensity

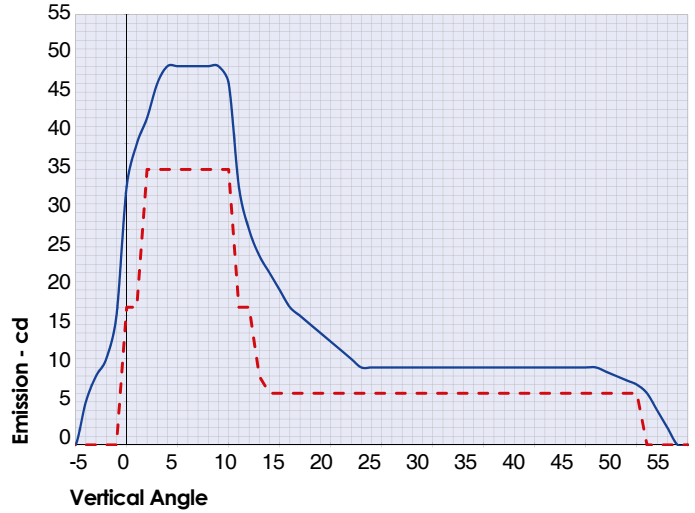

— L810-LXS-B Exde average emission level
- - - ICAO ANNEX 14 low intensity type B Minimum Required Intensity

BEACON FRONT VIEW

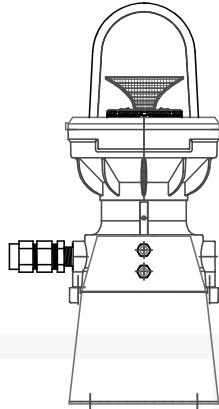

BEACON SIDE VIEW

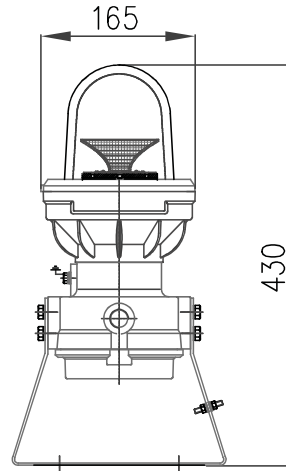

BEACON TOP VIEW

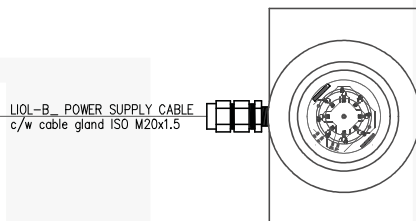

FIXING DETAILS

