

# MEDIUM INTENSITY

## MEDIUM INTENSITY OBSTRUCTION LIGHT

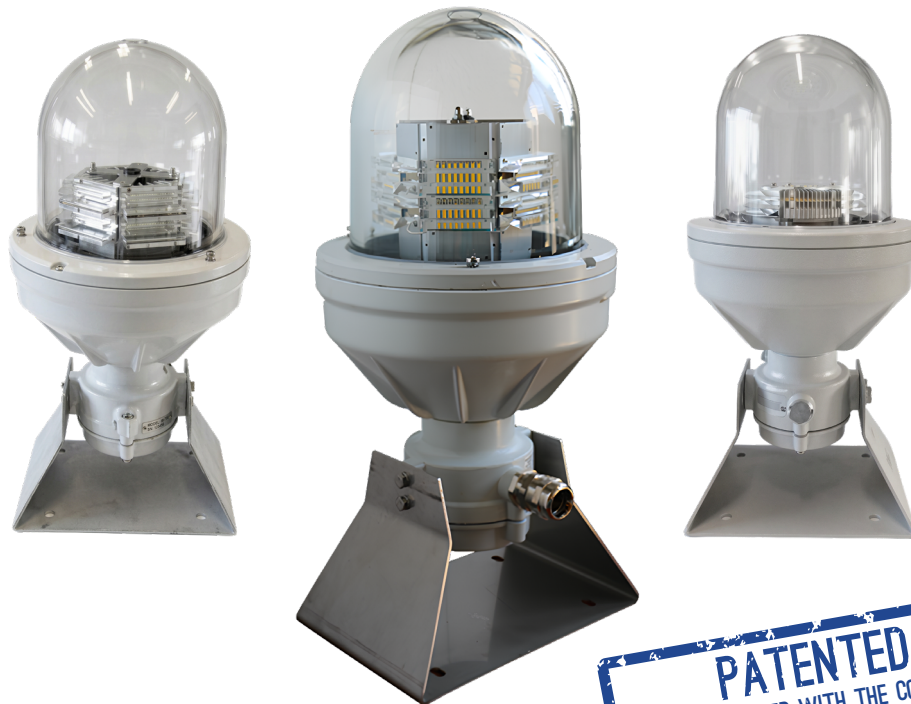

**PATENTED**  
PATENT ACHIEVED WITH THE CONTRIBUTION  
OF REGIONE LOMBARDIA CALL FOR BIDS  
"RESEARCH & INNOVATION MEASURE F"

According to ICAO - Annex 14 Medium Intensity Obstruction Lights - Type A Ex, B Ex or C Ex - have to be used where the obstacle is particularly large and the height of the surrounding ground is more than 45m in hazardous areas. Medium Intensity Obstacle Lights Type A Ex and C Ex have to be used alone, whereas Medium Intensity Obstacle Lights, Type B Ex, should be used either alone or in combination with Low Intensity Obstacle Lights, Type B Ex.

The Medium Intensity Obstruction Lights Type A Ex is white flashing.

The Medium Intensity Obstruction Lights Type B Ex is red flashing.

The Medium Intensity Obstruction Lights Type C Ex is red steady burning.



# MEDIUM INTENSITY

## MIOL-B Ex / MIOL-C Ex

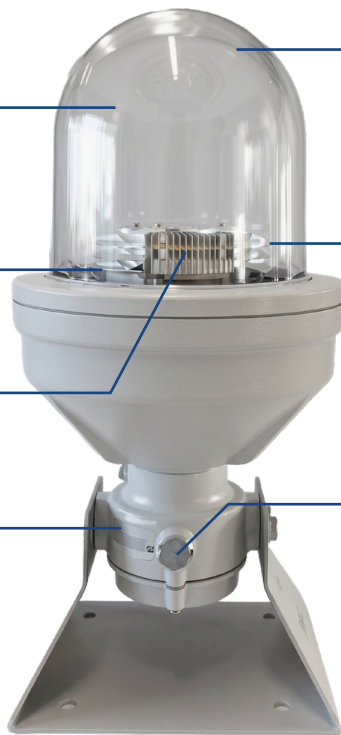

Twilight sensor\*

Borosilicate glass cover protection

Stabilised light output:  
- 2.000cd

Based on LED technology  
- Red flashing light (MIOL-B)  
- Red steady burning light (MIOL-C)

Standard circuits or TWIN\*  
Infrared version\*

Thread M25

RAL 7035 painted aluminium body lamp

\*in option

# IP66

Medium Intensity Obstruction Light is according to ICAO (Medium Intensity – Type B or C), FAA (Type L-864) and ATEX certified.

This beacon is the ideal solution for an **efficient, lightweight and compact obstacle signalling**.

**MIOL-B Ex** emits a **red flashing light**, while **MIOL-C Ex** emits **red steady burning light**.

### CERTIFICATION



### COMPLIANCE



### FEATURES



### APPLICATION



# MEDIUM INTENSITY

## MIOL-B Ex AND MIOL-C Ex TECHNICAL SPECIFICATIONS

### OPTICAL FEATURES

- Based on LED technology
- RED light 2.000cd
- Cd emission @ -0,5° and +4°
- Horizontal beam radiation: 360°
- Vertical beam spread: 4°
- PMMA lens (PMMA)
- Light output alignment device
- ATEX execution: Ex II 2GD Ex de IIC T4 Gb  
Ex tb IIIC T135°C Db IP66
- IECEx execution: Ex db e IIC T4 Gb Ex tb  
IIIC T135°C Db IP66

### GENERAL OPTIONS

- Horizontal beam radiation: 180°
- Power supply AC or DC
- GPS (Global Position System) Sincro
- Infrared version
- Fault alarm

### TWIN VERSION OPTIONS

- Twin version: two galvanically separated circuits in the same fixture
- Fault alarm
- Automatic changeover from normal to backup light
- Infrared version

### MECHANICAL FEATURES

- Borosilicate glass cover protection
- RAL 7035 painted aluminium body lamp
- Degree of protection: IP66
- Operating temperature: -52°C to +60°C
- Storage temperature: -52°C to +60°C
- Lamp unit weight: 15kg

### ORDER CODE

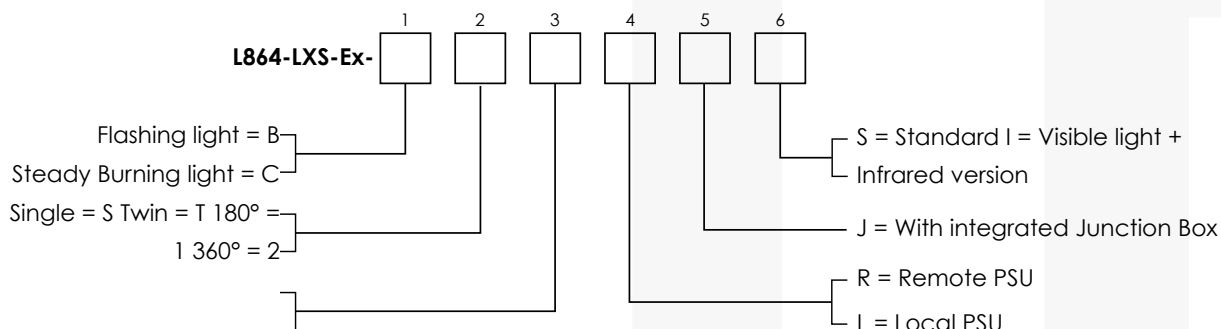

### APPLY TO

- Stack - Chimney - Tower crane
- Offshore Platform
- Chemical and petrochemical plant

### INFRARED VERSION OPTIONS

- IR Wavelength - 850nm

### ELECTRICAL FEATURES

- Alarm/remote status control
- Electronic Control parts installed outside the beacon (see pag. 18)
- Average power consumption:
  - @20fpm: 9W
  - @40fpm: 12W
  - @60fpm: 15W
- Average power consumption for MIOL-C Ex (Steady burning): 54W
- LED feeded at constant current
- Lightning protection
- No RF-radiations
- Range section of connectable conductors: da 0,5 a 2,5 mm2

### CERTIFICATIONS

- ATEX certificate no. INERIS 01ATEX0019x
- ENAC approvazione nr. 0135182/ENAC/CIA
- DGAC/STAC approval nr. 2013A037
- IECEx certificate no. IECEx INE\_15.0031X
- ASD 404 certificate no. ASD404/CERT/024/2017
- CE marking

### COMPLIANCE

- ICAO Aerodromes -Annex 14 Vol. 1, Chapter 6: Medium intensity, Type B flashing obstacle light MIOL-B type or Type C steady burning obstacle light MIOL-C type
- FAA AC150/5345-43F E.B. #67 type L-864 o Twin L-864
- Airport Standard Directive - Malesysian Regulation [ASD404]

# MEDIUM INTENSITY

## MIOL-B Ex AND MIOL-C Ex TECHNICAL SPECIFICATIONS

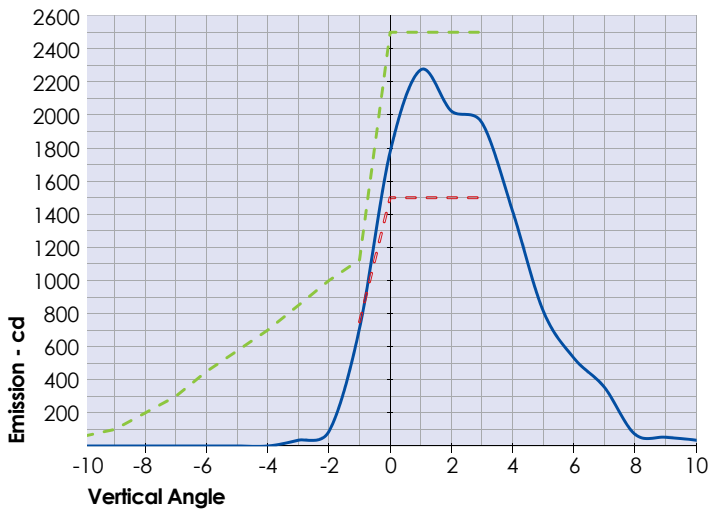

- L864-LXS-Ex-B/C average emission level at 90°C ambient temp.
- - - ICAO ANNEX 14 medium intensity type B/C Min. Required
- - - Intensity ICAO ANNEX 14 medium intensity type B/C Max.

BEACON FRONT VIEW

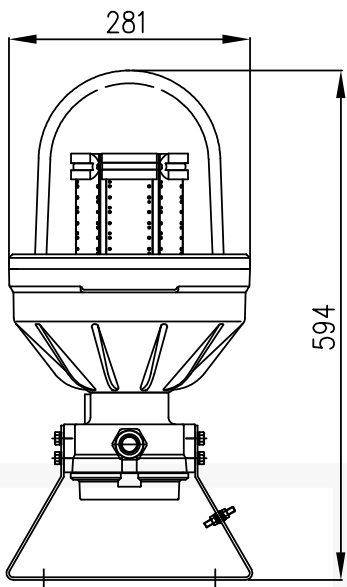

BEACON SIDE VIEW

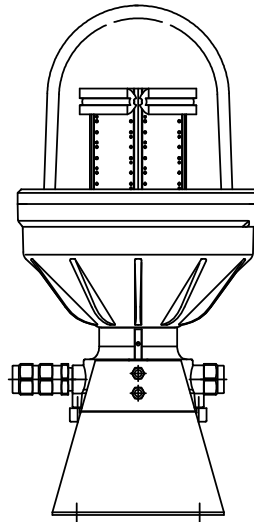

FIXING DETAILS

