

SEAPLANE AIRPORT LIGHT BEACON MEDIUM INTENSITY L801S-LXS



According to FAA AC150/5345-12, an **L801S Seaplane Aeronautical Beacons should be provided at sea-based airports intended for use at night.**

L801S Beacon shall be provided where the airport, due to the location or high background luminance, cannot be easily identified from the air by other identification means.

The device displays alternate white/yellow flashing light with 22-26 flashes per minute.



FAA AERONAUTICAL BEACONS

SEAPLANE AIRPORT BEACON MEDIUM INTENSITY L801S-LXS



NOTE: electronic beacon driver in a separate enclosure

IP66



LUXSOLAR L801S-LXS Seaplane Aeronautical Aerodrome Beacon is **compliant to FAA rule**.

With high quality and **ultra-bright LEDs, customized lenses and patented shape for optimum light emission and beacon cooling** LUXSOLAR L801S-LXS product is the most **up-to-dated and technologically advanced Aeronautical Beacon**.

This LED device is designed to **not contain any electronic component** (that is available in a separate control local panel): a huge **advantage in terms of increased life-time and suitability to all environments** (beacons can stand extreme weather conditions) and in terms of an **easy maintenance** (in case of maintenance or periodic checks on electronic components, these can be done easily).

CERTIFICATION



COMPLIANCE



FEATURES



TYPICAL APPLICATION



FAA AERONAUTICAL BEACONS

SEAPLANE AIRPORT BEACON MEDIUM INTENSITY L801S-LXS TECHNICAL SPECIFICATIONS

OPTICAL FEATURES

- Based on LED technology
- 50.000cd WHITE light / 20.000cd YELLOW light - Flashing 22-26fpm
- Horizontal beam radiation 360°
- Vertical beam spread from -3° to +7°
- PMMA lens
- Light output alignment device

MECHANICAL FEATURES

- Anodised aluminium body, painted yellow
- Borosilicate glass cover protection
- Silicon rubber, VMQ
- Base wind collector and internal heat sink for optimum cooling
- Degree of protection: IP66
- Anti-condensation Gore-Tex valve
- Operating temp.: -30°C to +50°C
- Lamp unit weight: 8kg approx.

BOX MECHANICAL FEATURES

- Enclosure material: mild steel, painted RAL 7035
- Surge arrester
- Fault alarm
- Overvoltage protection

ELECTRICAL FEATURES

- Power supply by LUXSOLAR controller box
- Suitable for 24Vdc or 115/230Vac power supply
- LED feeded at constant current
- No RF - Radiations

OPTIONS

- Beacon support bracket
- GPS (Global Position System) syncro

APPLY TO

- Airports intended for use at night and that can not be easily identified from the air by other means.

CERTIFICATIONS

- CE marking

COMPLIANCE

- FAA AC150/5345-12 lamp type L-801S

PART NUMBER

- **L801S-LXS-230VAC**
- **L801S-LXS-24VDC**

FAA AERONAUTICAL BEACONS

SEAPLANE AIRPORT BEACON MEDIUM INTENSITY L801S-LXS TECHNICAL DRAWING

L801S
BEACON

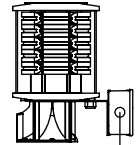

L801S BEACON POWER SUPPLY CABLE
11G1.5sqmm (BY OTHERS)

AWL CONTROL PANEL

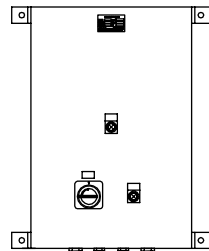

INCOMING POWER SUPPLY CABLE
(BY OTHERS)

REMOTE ENABLE SIGNAL CABLE
(BY OTHERS)

FAULT SIGNALS CABLE
(BY OTHERS)

FAA AERONAUTICAL BEACONS

SEAPLANE AIRPORT BEACON MEDIUM INTENSITY L801S-LXS TECHNICAL DRAWING

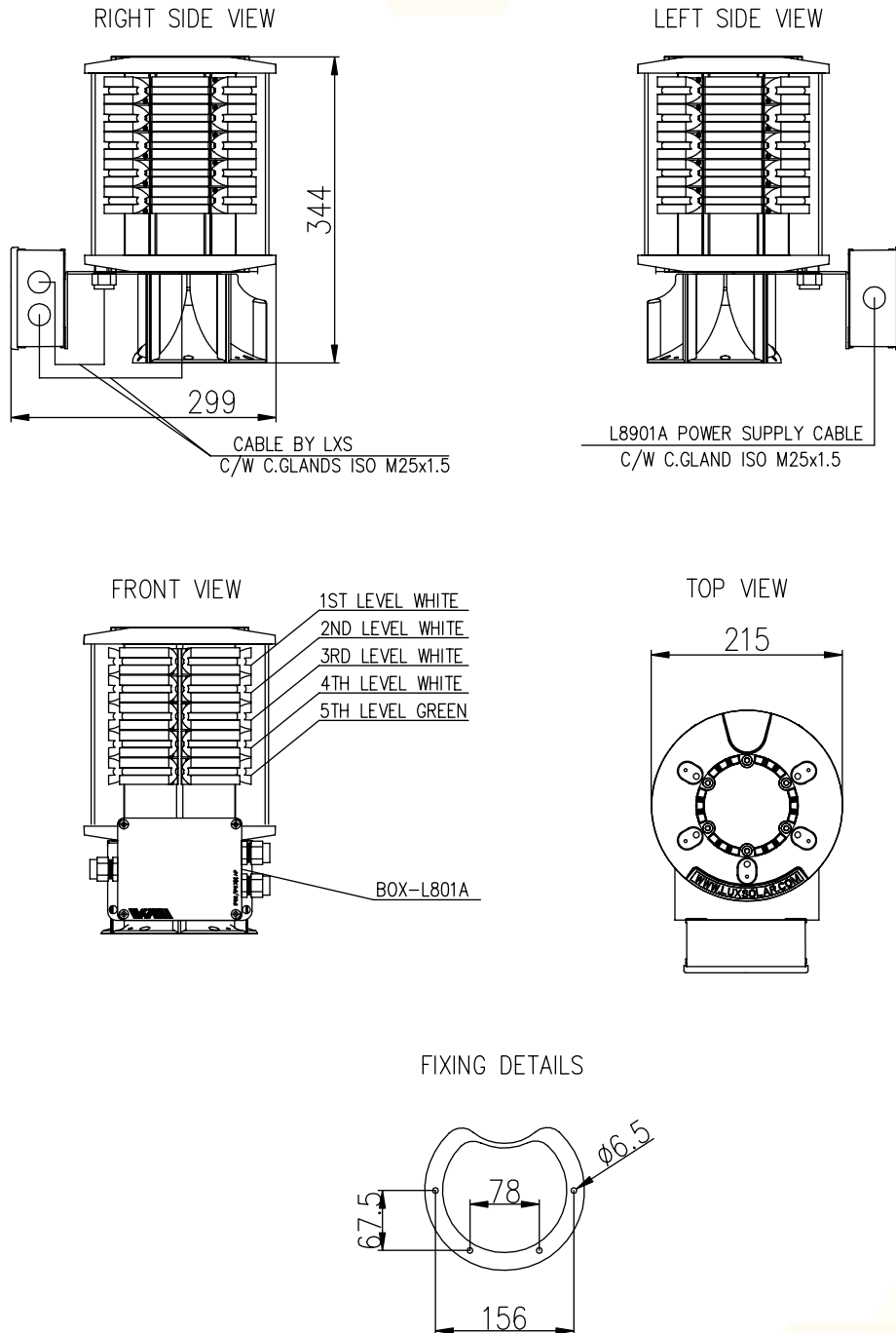

FAA AERONAUTICAL BEACONS

SEAPLANE AIRPORT BEACON MEDIUM INTENSITY L801S-LXS TECHNICAL DRAWING

